

Safety in working with lift trucks

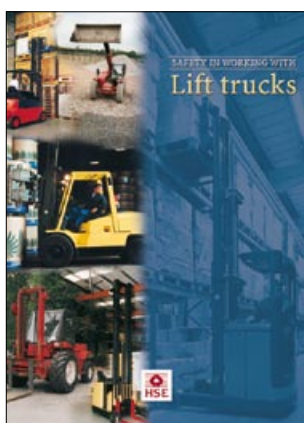

This is a free-to-download, web-friendly version of HSG6 (Third edition, published 2000). This version has been adapted for online use from HSE's current printed version.

You can buy the book at www.hsebooks.co.uk and most good bookshops.

ISBN: 978 0 7176 1781 4

Price £6.50

Lift trucks are widely used throughout industry for moving materials and goods, but they also feature prominently in workplace accidents. Even an incident not causing injury may result in costly damage to lift trucks, buildings, fittings and the goods being handled, and may disrupt work.

This guidance is relevant for anyone with responsibility for the safe operation of lift trucks, eg employers, controllers of worksites, managers, supervisors or operators. Other people involved with lift trucks, eg trade union health and safety representatives, may also find it useful. However, this guidance does not replace formal training.

The main areas covered are: the law; types of lift truck; lift truck operators; training; authorisation to drive; the working area; protecting pedestrians and operators; operation of lift trucks; trailers and loading platforms; maintenance; and two appendices covering training bodies and medical standards for lift truck operators.

© Crown copyright 2000

First published 1979
Second edition 1993
Third edition 2000
Reprinted 2002, 2003, 2008

ISBN 978 0 7176 1781 4

All rights reserved. No part of this publication may be reproduced, stored in a retrieval system, or transmitted in any form or by any means (electronic, mechanical, photocopying, recording or otherwise) without the prior written permission of the copyright owner.

Applications for reproduction should be made in writing to: Licensing Division, Her Majesty's Stationery Office, St Clements House, 2-16 Colegate, Norwich NR3 1BQ or by e-mail to hmsolicensing@cabinet-office.x.gsi.gov.uk

This guidance is issued by the Health and Safety Executive. Following the guidance is not compulsory and you are free to take other action. But if you do follow the guidance you will normally be doing enough to comply with the law. Health and safety inspectors seek to secure compliance with the law and may refer to this guidance as illustrating good practice.

Acknowledgements

HSE gratefully acknowledges the help given by the following organisations:

Barlow Handling
Hereford Fork Trucks (HFT)
Lansing Linde

Contents

Introduction 5

- Management of lift truck operations 5
- Who should read this guidance? 5
- The law 5

Types of lift truck 7

- Industrial counterbalance lift truck 7
- Industrial reach truck 8
- Rough-terrain counterbalance lift truck 8
- Telescopic materials handler 8
- Side-loading lift truck 9
- Pedestrian-controlled lift truck 9
- Large lift truck 9

Lift truck operators 10

- Selection of operators and trainees 10
- Medical considerations 10

Training 11

- Stages of training and other considerations 11
- Testing 13

Authorisation 13

The working area 13

- Parking areas 15

Protecting pedestrians and operators 15

- Pedestrians 15
- Operators 16

The lift truck 17

- Risks arising from motive power 22
- Attachments 23

Operation of lift trucks 26

- Dos and don'ts 26
- Stacking and de-stacking 28
- Stacking with counterbalance lift trucks 28
- De-stacking with counterbalance lift trucks 30
- Reach trucks 31
- Stacking with reach trucks 31
- De-stacking with reach trucks 33
- Working platforms 34
- Masted rough-terrain counterbalance lift trucks 34
- Telescopic materials handlers 35
- Side-loading lift trucks 36
- Pedestrian-controlled trucks 37

Trailers and loading platforms 37

Maintenance 37

Appendices

1 Accrediting bodies 39

2 Medical standards for lift truck operators 39

References and Further reading 43

Introduction

1 Lift trucks are widely used throughout industry for moving materials and goods, but they also feature prominently in worksite accidents. Every year there are about 8000 lift truck accidents resulting in injury, on average ten of them fatal. These injuries cause suffering for the people involved and their dependants, and often incur heavy costs for the employer's business. Even an incident not causing injury may result in costly damage to lift trucks, buildings, fittings and the goods being handled, and may disrupt work.

Management of lift truck operations

2 There are a few simple measures which can be taken to prevent lift truck accidents. Examples of these are:

- (a) managing lift truck operations using safe systems of work;
- (b) provision of adequate training for operators, supervisors and managers;
- (c) using suitable equipment for the job to be done;
- (d) laying out premises in such a way as to ensure that lift trucks can move safely;
and
- (e) ensuring that lift trucks and premises are maintained properly.

Who should read this guidance?

3 This guidance is relevant for everyone with responsibility for the safe operation of lift trucks, for example employers, controllers of worksites, managers, supervisors or operators. Others involved with lift trucks, such as trade union health and safety representatives, may also find it useful. However, this guidance does not replace formal training.

The law

4 Employers have a duty under health and safety law to ensure, as far as is reasonably practicable, the health, safety and welfare of their employees. The main legislation applying to the use of lift trucks is:

- (a) the Health and Safety at Work etc Act 1974 (HSW Act);¹
- (b) the Management of Health and Safety at Work Regulations 1999;²
- (c) the Provision and Use of Work Equipment Regulations 1998;³
- (d) the Lifting Operations and Lifting Equipment Regulations 1998;⁴
- (e) the Workplace (Health, Safety and Welfare) Regulations 1992;⁵ and
- (f) the Construction (Design and Management) Regulations 2007.⁶

5 The **Management of Health and Safety at Work Regulations 1999**² require a risk assessment to be carried out to identify the nature and level of risks associated with a work activity. Appropriate precautions need to be taken to eliminate or control these risks. A proportionate response according to the risk is required. The higher the level of risk identified through the assessment, the greater the measures that will be needed to reduce it. Risk assessment provides the basis for safe systems of work to eliminate or reduce risks as far as possible. Safe systems of work are formal procedures which should be followed to ensure that work is carried out safely. They are necessary where risks cannot be controlled adequately by other means. Employers must ensure that the systems of work to be followed are properly implemented and monitored, and that details have been given to those at risk.

6 The **Provision and Use of Work Equipment Regulations 1998**³ apply to all work equipment. They require that:

- (a) work equipment should be suitable for the purpose for which it is used or provided, and should be properly maintained and inspected at suitable intervals;
- (b) where the use of work equipment is likely to involve specific risks, the use, maintenance etc of that equipment is restricted to people given the task of using and/or maintaining it; and
- (c) users, supervisors and managers have received adequate training for purposes of health and safety, including:
 - (i) training in the methods which may be adopted when using work equipment;
 - (ii) any risks which such use may entail; and
 - (iii) precautions to be taken.

The Regulations also require that lift trucks which carry a seated ride-on operator should be fitted with a restraining system, such as a seat belt, if risk assessment indicates that there is a risk of the vehicle rolling over and the operator falling from the operating position and being crushed between the truck and the ground.

7 The **Lifting Operations and Lifting Equipment Regulations 1998**⁴ deal with specific hazards/risks associated with lifting equipment and lifting operations. They replaced most sector-specific legislation on lifting to create a single set of regulations that apply to all sectors. Management should ensure that every lifting operation involving a lift truck is:

- (a) properly planned by a competent person;
- (b) appropriately supervised; and
- (c) carried out in a safe manner.

For most lift truck work, planning will usually be a matter for the operator, who should therefore have the appropriate training, knowledge and expertise. While experienced lift truck operators may not be under direct supervision every time they carry out routine lifts, they may need to be supervised if required to lift an unusual load, or to lift in potentially hazardous conditions.

8 **The Workplace (Health, Safety and Welfare) Regulations⁵** require that workplaces should be organised to ensure that vehicles and pedestrians can move around safely. This includes:

- (a) sufficient lighting to enable people to work and move around safely (including not obscuring lights by stacking goods in front of them);
- (b) construction of floors and traffic routes to ensure that they are suitable for the purpose for which they will be used and do not expose users to health and safety risks;
- (c) organisation of traffic routes to enable pedestrians and vehicles to circulate safely; and
- (d) the need to ensure that doors or gates which can be pushed open from either side give a clear view, when shut, of the space close to both sides.

9 More detailed advice on these and other legal requirements is available in the Approved Codes of Practice (ACOPs) and guidance listed in the *References* and *Further reading* sections at the end of this publication.

Types of lift truck

10 This publication gives general guidance on the safe operation and use of lift trucks equipped with fork arms. The same principles apply to other types of lift truck, such as industrial telescopic trucks, and to lift trucks equipped with attachments other than fork arms. In all cases the operating instructions of the manufacture or authorised supplier* should be followed. It does not cover the use of order-picking trucks, straddle carriers, industrial tractors or platform trucks.

11 Although the lift trucks illustrated and described below are the main types covered by this guidance, it does not form an exhaustive list. Descriptions of some of the types of attachments that are available are given in paragraphs 67–70.

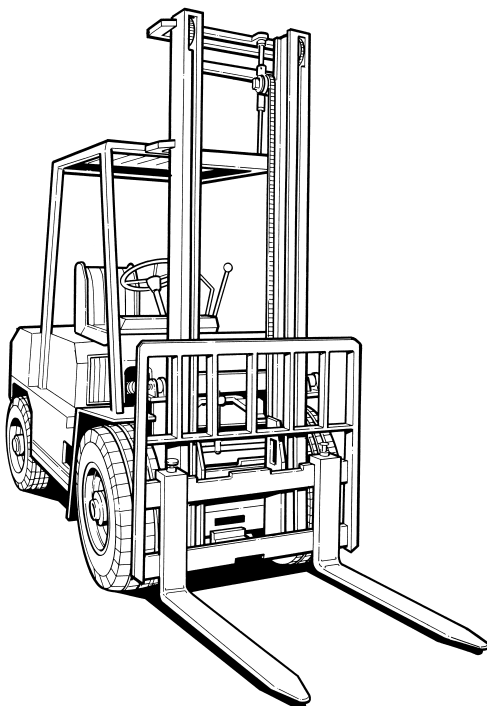

Industrial counterbalance lift truck

This has a counterweight to balance the load on the fork arms. The fork arms and load project out from the front of the machine. Loads can be raised or lowered vertically and the mast may be tilted forwards or backwards up to 15° (but in practice more usually about 5°). This type of lift truck is only suitable for use on substantially firm, smooth, level and prepared surfaces. A wide range of attachments is available.

Figure 1 Industrial counterbalance lift truck

* The term 'authorised supplier' used throughout this guidance means the authorised representative of the manufacturer.

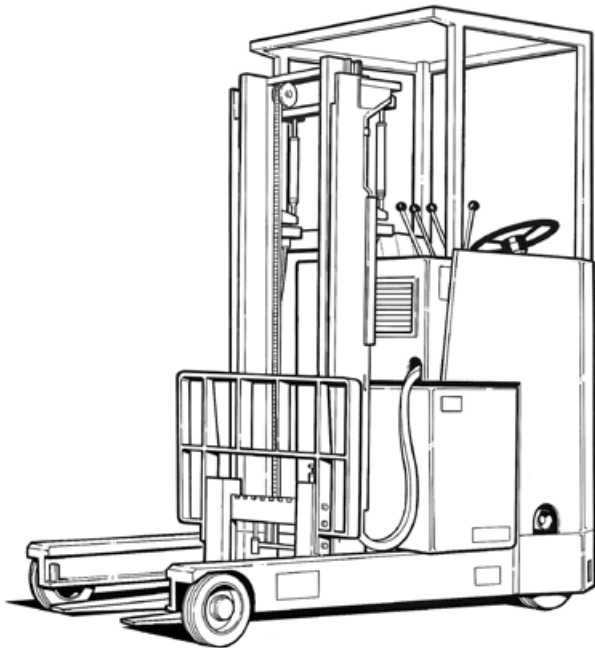

Figure 2 Industrial reach truck

Industrial reach truck

This is so called because the mast is moved forwards or reached out to pick up the load. For travelling, the load is reached back and carried within the wheelbase. This allows greater manoeuvrability in areas where space is restricted. This type of lift truck is only suitable for use on substantially firm, smooth, level and prepared surfaces and is particularly used in warehouses.

Rough-terrain counterbalance lift truck

This is similar in design to the industrial counterbalanced lift truck but is equipped with larger wheels and pneumatic tyres, giving it greater ground clearance. It has greater ability to operate on uneven and soft ground and is mainly used in the construction industry and in agriculture. It may be used with a range of attachments.

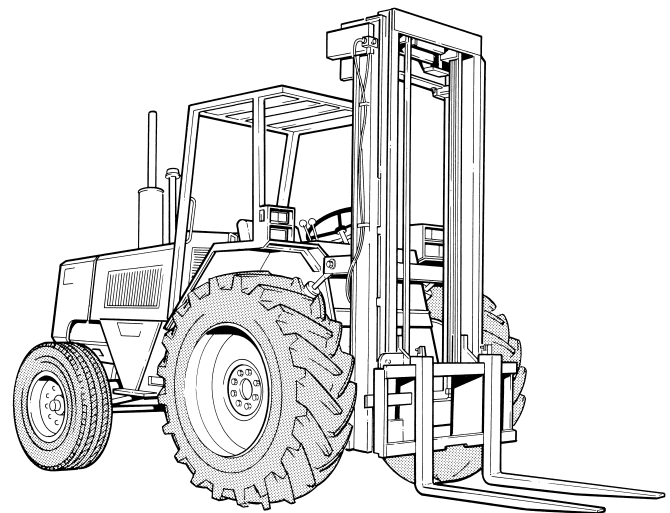

Figure 3 Rough-terrain counterbalance lift truck

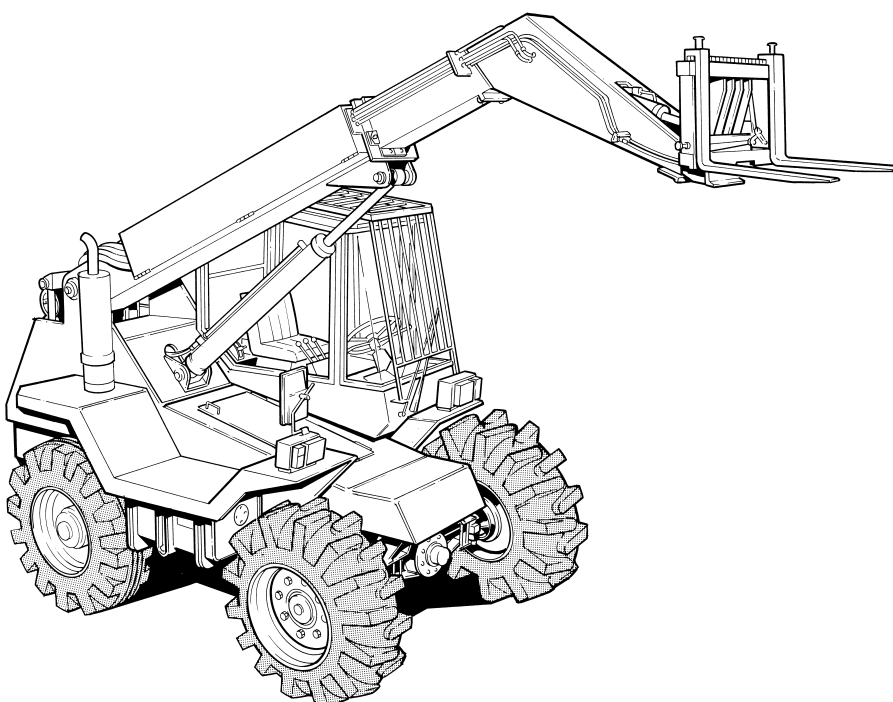

Figure 4 Telescopic materials handler

Telescopic materials handler

This is fitted with a boom that is pivoted at the rear of the machine. The boom is raised and lowered by hydraulic rams. In addition, the boom can be extended or retracted (telescoped) to give extra reach or height. These machines may be two- or four-wheel drive, and have two-wheel, four-wheel or crab steering. They are used mainly in agriculture and the construction industry. A range of attachments may be used with them.

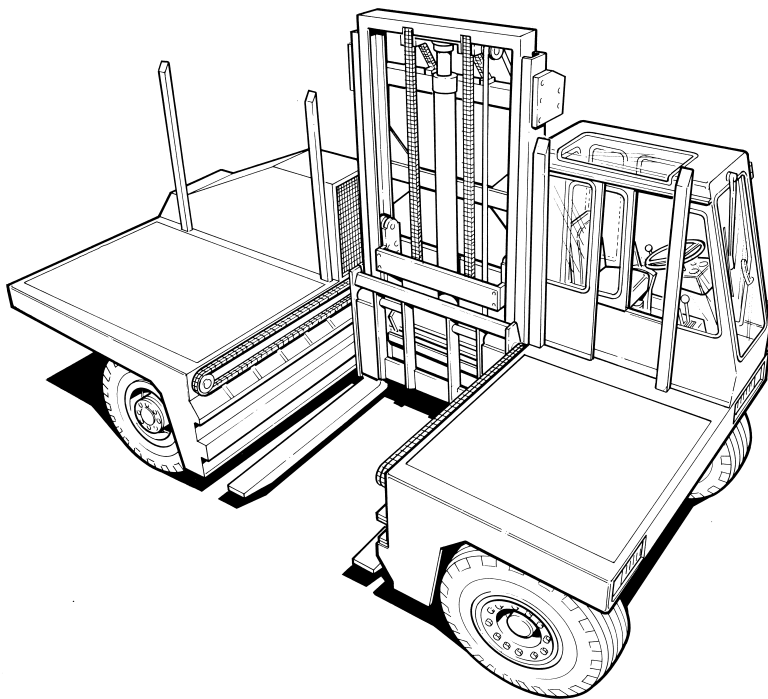

Figure 5 Side-loading lift truck

Pedestrian-controlled lift truck

This has a limited lift height, usually not greater than two metres. It may be electrically or manually powered for lifting and for traction. The operator walks with the machine and controls it with a handle.

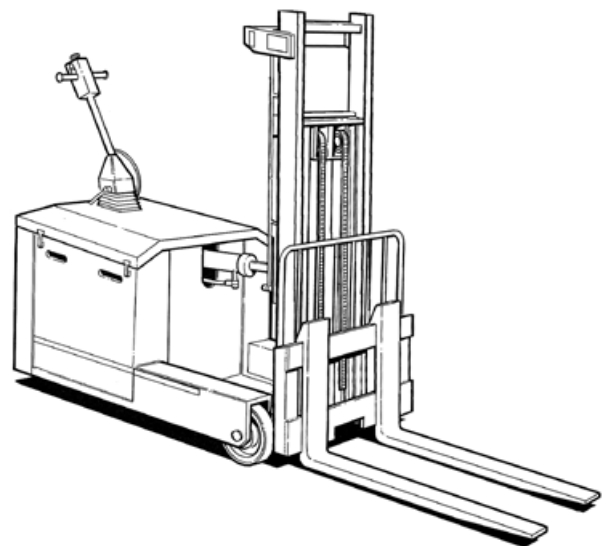

Figure 6 Pedestrian-controlled lift truck

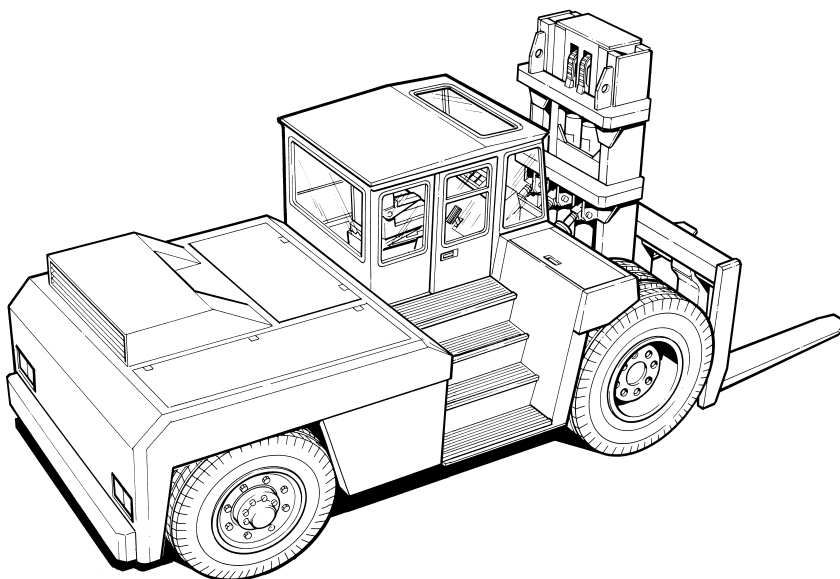

Figure 7 Large lift truck

Side-loading lift truck

The operator is positioned at the front and to one side of the lift truck. The load is carried on the deck, the mast being traversed out sideways to pick up or set down the load. This type of lift truck is used for stacking and moving long loads such as bales of timber and pipes, and may be fitted with stabilisers for use when picking up or setting down loads.

Large lift truck

This may be either masted or telescopic, and is often fitted with a spreader for lifting freight containers. The spreader may attach to the side or top of the container. These are specialist lift trucks used mainly in container terminals.

Lift truck operators

12 No one should be permitted to operate a lift truck unless he or she has been selected, trained and authorised to do so. The Approved Code of Practice and guidance *Rider-operated lift trucks: Operator training*⁷ provides practical guidance on the training necessary for the safe operation of rider-operated lift trucks.

Selection of operators and trainees

13 Potential lift truck operators should be selected carefully. Employers should choose people who have shown themselves to have a reliable and mature attitude to their work, and who have the ability to do the job in a responsible manner. The safe control and operation of lift trucks calls for a reasonable degree of both physical and mental fitness, and intelligence.

14 Lift truck operators should be over the minimum school-leaving age (except in docks, where they must be at least 18 years old). Advice on the Health and Safety (Young Persons) Regulations 1997, which apply to people under 18, is contained in *Young people at work – A guide for employers*.⁸ The immaturity of young people, together with their lack of experience and absence of awareness of existing or potential risks, should be taken into account before they are selected for training as lift truck operators. Minimum ages specified in road traffic legislation apply when lift trucks are on public roads.

15 It may be useful to apply a selection test to avoid wasteful attempts to instruct unsuitable trainees. Advice on trainability assessment can be obtained from the organisations listed in Appendix 1.

Medical considerations

16 People selected to operate lift trucks should be free from physical defects that might pose a threat to their own health or safety or the safety of others who might be affected by their operation of lift trucks. However, people with disabilities need not be excluded from work with lift trucks, and medical advice should be obtained about their suitability for the particular duties that will be required of them.

17 Fitness for operating should always be judged individually. Some people with disabilities have developed skills which compensate for their disability. A risk assessment should be carried out to identify hazards associated with the job and working environment and to ascertain the areas of concern that will need to be taken into consideration.

18 It is good practice for all operators and potential operators to be screened for fitness before employment and again at regular intervals in middle age. Examination at age 40 and thereafter at five-yearly intervals up to age 65 is recommended. Operators over 65 should be screened annually. Examination is also recommended in all cases after an accident or sickness absence of more than one month, or after a shorter period if it appears likely that the illness may affect fitness to operate. Should any operator or employer suspect or become aware of a condition which might affect ability to operate a lift truck, then examination should also take place. It is recommended that any requirement for medical screening and/or examination should be agreed between employer and employee in advance under a contract of employment.

19 Where an employee is taking drugs prescribed by a medical practitioner it should be established that these will not affect operating ability (see Appendix 2).

20 Points to be considered concerning the normal level of fitness required are:

- (a) *General*. Lift truck operators should usually have full movement of the trunk, neck and limbs, and normal agility. However, a very experienced worker who loses a limb may be successfully re-employed after retraining. A stable disposition is required, but a history of previous mental illness should not necessarily preclude selection. An individual who is dependent on alcohol or non-prescribed drugs should not be employed as a lift truck operator;
- (b) *Vision*. Proper guidance of the lift truck and its load depends upon good judgement of space and distance and this generally requires the effective use of both eyes, although some people with monocular vision can undertake certain kinds of lift truck work satisfactorily. Distance vision should be of the same standard as for driving a car on public roads. If distance vision is corrected by glasses or contact lenses these should always be worn while operating a lift truck;
- (c) *Hearing*. The ability to hear instructions and warning signals is important, but if a risk assessment specific to the job and the individual indicates that deafness does not constitute a hazard then it should not disqualify someone from operating a lift truck;
- (d) *Epilepsy*. This should not debar a worker from operating a lift truck if he/she is eligible for an ordinary driving licence (ie has been free from epileptic attack for one year) but any recurrence of seizures must always be reassessed medically. Flashing beacons may trigger epileptic fits.

The medical standards which are required for lift truck operators are set out in more detail in Appendix 2. Further advice is available from the Employment Medical Advisory Service (your local office is listed in the telephone directory under Health and Safety Executive).

Training

21 Training in safety is most important for all operators and should be provided as an integral part of their training, not separately. Operators should be trained to the level of skill necessary to work a lift truck safely and efficiently. The following paragraphs give outline guidance on training. Detailed advice on training is given in *Rider-operated lift trucks: Operator training*.⁷

22 Employers should keep records of all training given to individuals, including conversion and refresher training, and of their performance in associated tests.

23 The training of supervisors of lift truck operators should include an appreciation of all the measures, as outlined in this guidance, which are necessary to ensure the safe use of lift trucks within the workplace. Managers should have an appreciation of the risks in the working environment and of the methods of minimising those risks.

Stages of training and other considerations

24 The training of operators should always include the three stages of training: basic, specific job and familiarisation. The first two stages of training, which can

be combined, should take place off the job (ie sheltered from production and other pressures). Familiarisation training needs to be done on the job, under close supervision. Lift truck operators, including occasional users, should be given the opportunity to put what they have learned during training into practice in the workplace.

25 Basic training should cover the basic skills and knowledge required to operate a lift truck safely and efficiently.

26 Specific job training should be tailored to the employer's needs and should include:

- (a) knowledge of the operating principles and controls of the lift truck to be used, especially where these relate to handling attachments specific to the job, or where the controls differ from those on which the operator has been trained. Routine inspection and servicing of that lift truck in accordance with the operator's handbook or with instructions issued by the manufacturer should be covered in so far as they may reasonably be carried out by the operator;
- (b) use of the lift truck in conditions the operator will meet on the job, for example slopes, confined areas, cold stores etc, and instruction on site rules, for example speed limits, safe systems of work (including measures to prevent use of trucks by unauthorised operators);
- (c) the work to be undertaken, for example loading and unloading particular kinds of vehicle.

27 After successful completion of the first two stages, operators should be given familiarisation training at the workplace under close supervision by someone with appropriate knowledge. Familiarisation training should cover the application, under normal working conditions, of the skills already learned, covering features of the work which it was not feasible to teach off the job, such as local emergency procedures etc.

28 Basic and specific job training should be carried out by a competent instructor either at the premises of a training organisation or on the employer's own premises. The training area should be suitable for manoeuvring, and closed to other activities and personnel while training is taking place. Details of the requirements for instructors are set out in *Rider-operated lift trucks – operator training*.⁷ Information on trainers, training courses and certification can be obtained from the organisations listed in Appendix 1.

29 The training requirements of newly recruited lift truck operators and existing operators whose working practices change, should be assessed and appropriate training provided. New recruits who have some experience of lift truck operation may need less training than those with no experience, provided they are competent and their experience is relevant.

30 An operator with basic training on one type of lift truck or handling attachment cannot operate others safely without additional conversion training.

31 Where supervisors identify poor operating practices, employers should take appropriate corrective action, including considering refresher training.

Testing

32 Continuous assessment should be made by the instructor of a trainee's progress to ensure that the required standards are achieved throughout training. At the end of training, a test should be taken to validate the training which has been provided.

Authorisation

33 Following satisfactory completion of training, employees should be given written authorisation by their employers to operate the type(s) of truck which the employer considers they are competent to operate. Authorisations may be issued on an individual basis and/or recorded centrally by employers. Employers will also need to ensure that they are satisfied with the continuing competence of authorised operators.

The working area

34 Employers should consider the safe movement of lift trucks and loads as part of their overall safety policy for people, plant and equipment.

35 Attention should be paid to reducing risks at points where lift trucks might meet other traffic or pedestrians, including areas where lift trucks load and unload other vehicles. When the use of lift trucks outside the workplace is unavoidable, for example to load or unload lorries which cannot enter the workplace and are parked on public roads, risk assessment should include the extra hazards, such as movement of road vehicles and pedestrians, which are not part of the work activity. This risk assessment should form the basis of a safe system of work, and planning of the lifting operation should take the extra risk into account.

36 Roads, gangways and aisles should have sufficient width and overhead clearance for the largest lift trucks using them to do so safely, whether loaded or unloaded, and, if necessary, to allow vehicles and loads to pass each other safely. Attention should be paid to reducing risks at points where lift trucks might meet other traffic or pedestrians, including areas where lift trucks load and unload other vehicles. Road humps are unsuitable for lift trucks and if possible should be avoided in areas where they operate. However, if road humps are used in these areas, gaps or by-passes should be provided for use by lift trucks. One-way traffic systems should be considered in order to reduce the risk of collisions.

37 Where possible, pedestrians should be prohibited from entering areas in which lift trucks are operating. Where this is not possible, an assessment of the risks to pedestrians should be made and, where necessary, means provided that adequately control the risks. Clear direction signs and the marking of doorways with the name of the building or departments concerned can help to avoid unnecessary traffic movements. Safety signs should conform to the Health and Safety (Safety Signs and Signals) Regulations 1996.⁹

38 Sharp bends and overhead obstructions should be eliminated or avoided as far as possible. Where hazards cannot be removed, the risk should be reduced by the use of barriers which are clearly marked, for example with black and yellow diagonal stripes. Where barriers cannot be used, signs, warning devices, mirrors etc should be used. Instructions to sound horns or restrict speed should be

considered. Flexible doors of transparent or translucent material may reduce risks where vehicles have to pass through. The lift truck operator should have a clear view through the closed doors before proceeding. Overhead obstructions should be clearly marked where lift trucks are operating.

39 The edges of loading bays, excavations and pits should be clearly marked, for example by black and yellow diagonal stripes (Figure 8), if lift trucks are operating nearby. Where possible, edges should be fitted with barriers (Figure 9).

Figure 8 Clearly marked edges of inspection pit

40 Operating areas should be as free as possible of obstructions, but features of the building, like support columns, pipework, racking or other plant, may need to be specially identified, protected by adequate impact barriers (Figure 10) and marked to improve their visibility.

41 It is important to select lift trucks which are suitable for use in all the conditions likely to be encountered in the workplace where they are to be used. Generally the surfaces used by lift trucks should be as level and firm as possible, and preferably surfaced with concrete or other suitable material. However, some lift trucks are designed to operate on rough or uneven surfaces. Potholes and accumulations of loose material on the ground are particularly hazardous to small-wheeled lift trucks.

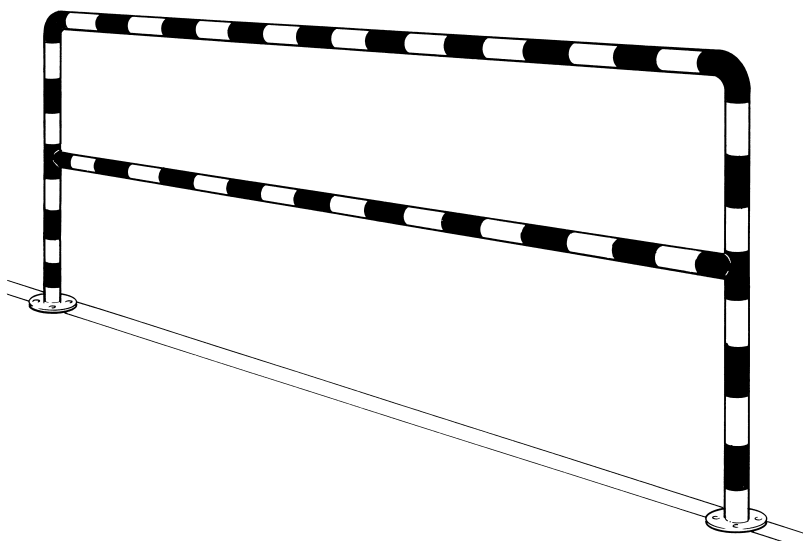
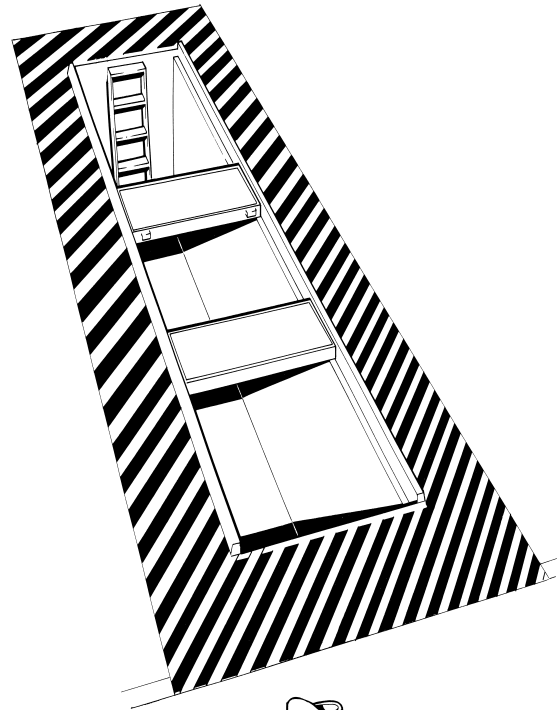

Figure 9 Clearly marked barrier

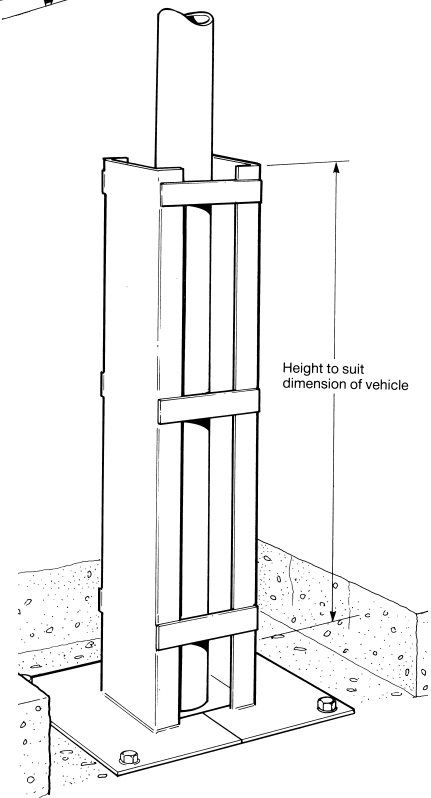

Figure 10 Impact barrier

42 Any gradient on which lift trucks have to operate should be as gentle as possible, and lift trucks should not move across a gradient unless designed for such work. Lift trucks should never be driven up or down gradients that exceed the maximum gradient specified by the manufacturer or authorised supplier.

43 Roadways both inside and outside buildings should be adequately lit, particularly:

- (a) at road junctions and rail crossings;
- (b) near buildings and plant;
- (c) in pedestrian areas;
- (d) where there is regular movement of vehicles and other mobile plant; and
- (e) in the area immediately inside a building where vehicles may pass from bright sunlight into the building.

44 Where possible, lighting should be arranged to avoid glare. Differences in light levels of the work areas and surrounding areas should be kept to a minimum. Further guidance is given in *Lighting at work*.¹⁰

Parking areas

45 Lift trucks should, as far as possible, be parked in a secure compound or in a supervised area where they will not be easily accessible to unauthorised people. These areas should, if practicable, be separate from operating areas. When the lift trucks are not in use, keys, or other devices which allow lift trucks to be operated, should be kept in a secure place, such as the supervisor's or gatekeeper's office, and only issued to authorised operators.

Protecting pedestrians and operators

46 People can be kept safe through safe systems of work and the provision of physical protection. Protective measures for lift truck operations might include the following:

Pedestrians

- (a) *Segregation of pedestrians*. Pedestrians should where possible be segregated from vehicle routes by a physical barrier (Figure 11); otherwise pedestrian routes should be clearly marked. Where it is not possible to provide a separate means of access and egress for pedestrians, other arrangements, such as the use of audible or visual warning devices, should be made to ensure their safety;
- (b) *Audible warning devices on lift trucks*. These vary from the simple manually operated horn to the automatic reversing bleeper. In deciding whether such measures will be effective, employers should take into account the number of



Figure 11 Arrangement of doors for separating pedestrian routes from traffic routes

lift trucks operating in the area, the background noise levels and the likely effect on overall noise levels. The requirements of the Noise at Work Regulations 1989¹¹ will also have to be met;

- (c) *Flashing beacons on lift trucks.* The use of these devices may be effective, particularly where lighting is poor or lift trucks operate intermittently, or where audible devices are likely to be ineffective. (Note: Epileptic fits may be triggered by flashing beacons; see medical considerations in Appendix 2.)
- (d) *High-visibility clothing.* Where the risks to pedestrians cannot be adequately controlled by other methods, high-visibility clothing should be worn by all pedestrians. In addition, lift truck operators should be provided with such clothing at all times and instructed to wear it whenever they leave the operating position of the lift truck.

Operators

- (a) *Roll-over protective structures (ROPS).* The masts of most vertical-masted lift trucks, provided they have sufficient strength and dimensions, will generally prevent the truck from doing more than tipping over onto its side. However, where there is a risk of a truck rolling over and crushing the operator, a ROPS should be fitted to minimise the risk to operators should roll-over occur. Telescopic materials handlers are capable of rolling over 180° or more, and will need a ROPS to protect operators if used in circumstances where there is a risk of roll-over.
- (b) *Restraining systems.* If risk assessment shows that a lift truck with a seated ride-on operator can roll over in use and there is a risk of the operator leaving the operating position and being crushed between the truck and ground, a restraining system, such as a seat belt, will be required. Restraining systems are also required on any lift truck which is fitted with a ROPS, to protect operators from the risk of injury resulting from 180° or more roll-over.
- (c) *Head protection.* Falling object protective structures (FOPS) should be fitted where there is a significant risk of falling materials endangering the operator. Where it is not practicable to fit such a structure, safety helmets should be

worn where there is a risk of head injury from falling objects. There are specific requirements for the construction industry contained in the Construction (Head Protection) Regulations 1989.¹²

- (d) Where practicable, loads should not be carried or suspended over areas occupied by people (this would apply mainly to telescopic materials handlers) or above unprotected workplaces usually occupied by workers. Where this is not practicable a safe system of work needs to be established to minimise risks.

47 Further guidance on general workplace transport safety is given in *Workplace transport safety: An employers guide*.¹³

48 Anyone driving a lift truck on the public road must comply with the appropriate road traffic legislation. Any questions regarding the need for driver and vehicle licensing when lift trucks are used on the road should be addressed to the Driver and Vehicle Licensing Agency, Longview Road, Morriston, Swansea, SA6 7JL, tel: 0870 2400009.

The lift truck

49 Health and safety legislation requires work equipment to be suitable and safe for its intended use and to be maintained in an efficient condition.

50 It is essential that people operating lift trucks or supervising their operation understand their characteristics. Lift trucks are designed to lift loads, move them and re-stack them in a different place. The mass of a counterbalance lift truck acts as a counterweight so that the load can be lifted and moved without the lift truck tipping (Figure 12a). However, the lift truck can be tipped forward if the load is too heavy (Figure 12b), if the load is incorrectly placed on the fork arms (Figure 12c), or if the lift truck is accelerated or braked harshly while carrying a heavy load. The stability of lift trucks is also affected by the forces generated when turning, especially at speed, or if the lift truck is tilted sideways by travelling across an incline for example, or by the wheels running into a pothole or over an obstruction. The danger of a lift truck being turned on its side is greater with the load in the raised position (Figure 12d) than in the lowered position (Figure 12e), and if the lift truck is turned during travel when unladen. Lift trucks should not travel with raised loads and should be driven with care when unladen, particularly when turning.

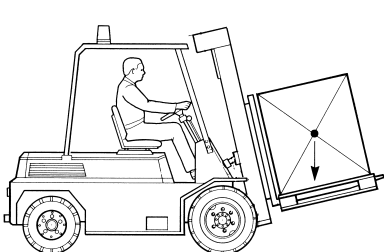

Figure 12a

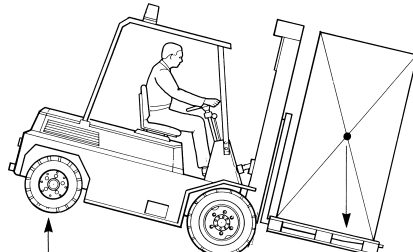

Figure 12b

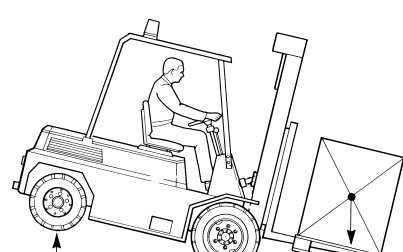

Figure 12c

51 With the mast reached out, a reach truck behaves like a counterbalance lift truck. When laden with the mast reached in, because the load is then within the wheel base, the reach truck is less likely to tip forwards but its sideways stability is reduced. If the load is then elevated and the mast tilted back, there is a risk of tipping sideways or even backwards (though tipping

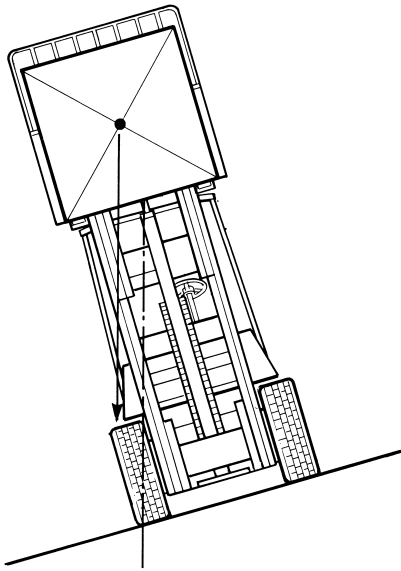

Figure 12d

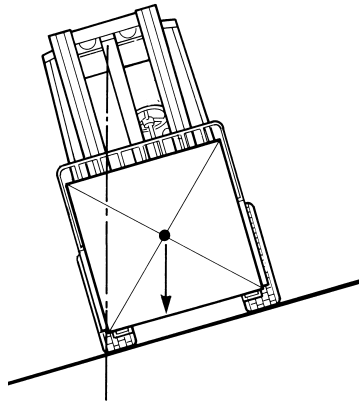

Figure 12e

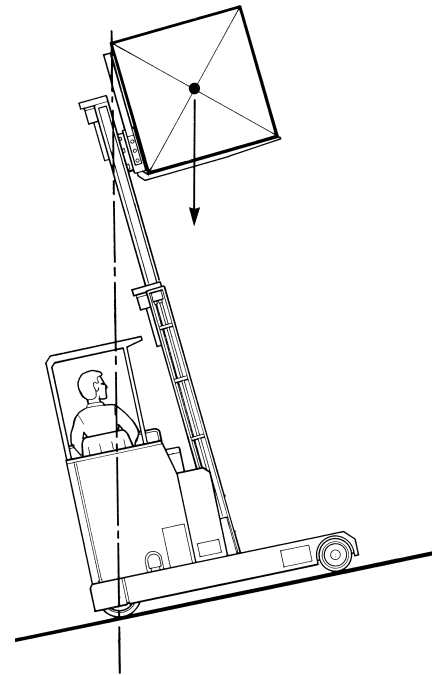

Figure 12f

backwards is likely to result in the truck falling on its side). This risk is increased if the load is high and the wheel base of the reach truck is short and on a slope (Figure 12f). The presence of potholes or bumps will increase the risk of instability in all situations. It is therefore essential that the truck does not travel with a raised load and that sloping and/or uneven surfaces which could affect the stability of the truck are avoided. Back tilt is normally extremely limited on reach trucks. Nevertheless, it is essential that the amount of back tilt used should not cause instability. Only sufficient back tilt to stabilise the load when it is being lifted should be used. The degree of back tilt should not be altered beyond that built in by the manufacturer.

52 The lift truck should be used in a way which ensures its stability under all foreseeable conditions.

53 Where operators are at risk of falling out and being crushed between any part of the lift truck and the ground if the truck overturns, a restraining system (for example a seat belt) should be fitted. Where a restraining system cannot be fitted, and the risks are sufficiently high, it may be necessary to use another lift truck which has such a system.

54 Operators and supervisors should be familiar with the following information, which should be shown on the lift truck:

- (a) name of the manufacturer (or authorised supplier) of the lift truck;
- (b) model designation;
- (c) serial number;
- (d) unladen weight (the unladen weight of an electric lift truck excludes the battery weight although the maximum and minimum authorised battery mass is shown on the truck. The battery weight is marked on the battery's own plate);

- (e) capacity;
- (f) load centre distance;
- (g) maximum lift height; and
- (h) inflation pressures if the lift truck is fitted with pneumatic tyres.

In addition, the functions of all the controls should be clearly marked so that they can be seen from the operator's position.

55 Lift trucks should not be loaded beyond their actual (safe) capacity. The actual capacity (safe working load) is a function of the rated capacity, lift height and load centre distance, the load centre distance being the distance from the centre of gravity of the load to the front face of the fork shank. This information is shown on the lift truck capacity data plate. It may be necessary to derate (reduce the value) to take into account where and how the lift truck is to be used, when using a carpet boom for example, or a drum clamp, or a crane jib on a lift truck with a safe working load determined for 'normal' lift truck use. Managers and supervisors need to ensure that those involved in lifting operations know when this may be necessary and that those undertaking the derating have sufficient competence. The information supplied by the truck and attachment manufacturers should be referred to whenever derating is carried out and in cases of doubt they should be contacted for advice.

56 Unless approved by the manufacturer or authorised supplier the weight of the counterweight should not be changed, as this will adversely affect the lift truck's stability and safety. On electric lift trucks, only batteries of the size and weight specified by the lift truck manufacturer should be used, as batteries are part of the counterweight and an incorrect weight will affect stability.

57 When obtaining or using a lift truck the following points should be noted:

- (a) *Lifting mechanism.* Lift trucks require thorough examination under the Lifting Operations and Lifting Equipment Regulations 1998, regulation 9.⁴ The scope, nature and frequency of the thorough examination should be set by a competent person, and at least the forks, chains, mast, cylinders and hoist mechanism should be included. Under the Provision and Use of Work Equipment Regulations 1998,³ regulation 6, those safety-related parts of the truck which are not covered by the thorough examination should be inspected periodically by a competent person;
- (b) *Wheels and tyres.* Lift trucks fitted with pneumatic tyres should not be used to lift loads unless the tyres are inflated to the correct pressure (the inflation pressure should be shown prominently on the lift truck). Tyre pressures should be checked on a regular basis using an appropriate pressure gauge to confirm that they are at the pressures recommended by the manufacturer. Tyres should also be checked for damage which may affect their safety. If the lift truck has wheels with split rims, nuts holding the sections of the rim together should be clearly identified so that they are not released in mistake for the nuts which fasten the wheel to the hub (Figure 13). When first inflating tyres on three-piece rims a protective guard or cage (Figure 14) should be used to minimise the danger if a ring breaks away. Tyres should be fully deflated before splitting wheels. Pneumatic tyres should be removed from rims before carrying out hot work on the rim, for example welding, as the tyre may explode due to ignition of hydrocarbon vapour in the tyre. Replacing a tyre on one side only may introduce a list if the tyre on the other side is also worn. Guidance

on the servicing of tyres on commercial wheels or divided wheels, which are sometimes encountered on lift trucks, is provided in *Health and safety in tyre and exhaust fitting premises*;¹⁴

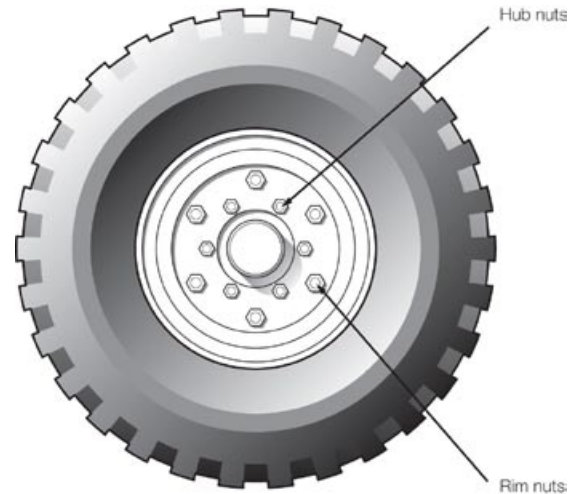

Figure 13 Wheel nuts - typical arrangement

(c) *Brakes*. Lift trucks should have an efficient braking system capable of stopping a laden lift truck smoothly and rapidly, and holding the lift truck when parked. The braking system should be properly maintained;

(d) *Horn*. A clearly audible warning device should be provided;

(e) *Falling object protective structures (FOPS)* (Figure 15). If lift truck operators are at significant risk of injury from objects falling



Figure 14 Inflating tyre using safety cage

on them while the lift truck is in use, a FOPS should be provided. This may be achieved by a suitably strong safety cab or protective cage which provides adequate protection in the working environment in which the lift truck is used. While the structure should not unreasonably obscure the operator's vision, the openings in it should be small enough to provide adequate protection;

(f) *Roll-over protective structures (ROPS)*. Where there is a risk of a truck rolling over and crushing the operator, a ROPS should be fitted. It should be strong enough to protect the operator in the event of a rollover. This should be combined with a restraining system (see Operators, page 16).

(g) *Load back rest extension* (Figure 15). A load back-rest extension should be fitted if the lift truck is used to move objects liable to fall on the operator. The load back-rest extension should be high enough to prevent the load rolling over the top of it;

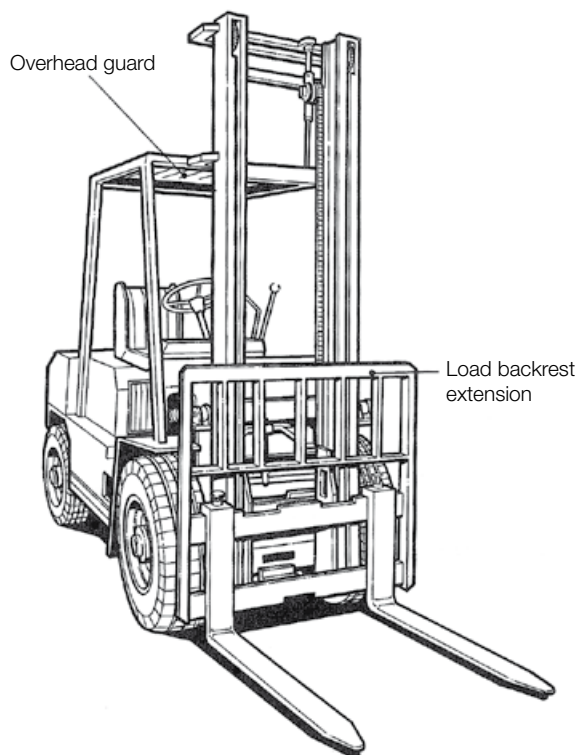

Figure 15 Falling object protective structure and load backrest extension

- (h) *Attachments*. Some loads can be handled more efficiently and safely by the use of suitable attachments, for example fork arm extensions, booms, rotating heads, drum clamps, paper roll clamps, bale clamps, load stabilisers etc;
- (i) *Dangerous moving parts*. Guards should be provided to prevent access to the dangerous moving parts of the lift truck which are within the operator's reach in the normal operating position, for example traps caused by telescopic mast sections, lifting chains etc;
- (j) *Lights*. Suitable lights should be provided at the front and rear if the lift truck has to be driven at night, or in areas with insufficient natural or artificial light, such as in drive-in racking. Consideration should be given to fitting a flashing yellow light on the top of the lift truck to warn other people;
- (k) *Noise*. When selecting lift trucks, consideration will need to be given to the likely effects on noise levels in the workplace by the use of particular types of lift truck and whether quieter ones could be used. Manufacturers are required to give information on the noise emission of their lift trucks. Further guidance on noise at work is given in *Reducing noise at work: Guidance on the Noise at Work Regulations*.¹¹
- (l) *Comfort*. Many operators have to sit on their lift truck for much of the working day so it is important that the seat is designed and maintained to lessen fatigue and discomfort, and prevent ill-health caused by vibration. The manufacturer's advice should be sought if the seat proves to be unreasonably tiring or passes on excessive vibration;
- (m) *Protection from adverse weather conditions*. Where lift trucks are used outside, adequate provision should be made to protect the operator from the effects of adverse weather conditions. Where possible, lift trucks fitted with cabs should be used. Lift truck operations should be halted where weather conditions are bad enough to adversely affect the performance of the lift truck or expose the operator to danger, for example excessive wind speed, poor visibility due to mist or fog, lightning or heavy rain. Bad weather, even after it is over, may leave unsafe conditions, for example waterlogged and unstable ground following a period of heavy rain;
- (n) *Unauthorised use*. Lift trucks should have facilities for preventing their use by anyone other than authorised users. Keys or other devices should be kept securely, with a custody system to prevent unauthorised use; and
- (o) *Hazardous substances*. The Control of Substances Hazardous to Health Regulations 2002 (as amended) (COSHH) require an assessment to be made of exposure to hazardous substances and, where necessary, appropriate control measures to be introduced. Examples of hazardous substances that may be encountered in lift truck operations are exhaust fumes from internal combustion engines, fuel oils and battery acid. When handling fuel oils or fuelling a lift truck, protective gloves should be worn. Where there is a possibility of battery acid being splashed, the minimum protection required is protective gloves and eye protection. Maintenance operations and certain loads may expose

people to other hazardous substances. These, and the methods to control exposure to them, should be identified by the assessment under the COSHH Regulations. Procedures to be followed in the event of spillage or leakage of hazardous substances should be established and all staff made aware of them. Appropriate first-aid facilities should be available. More information on the COSHH Regulations is available in the *General COSHH ACOP (Control of substances hazardous to health)*.¹⁵ For more information on the provision of first aid see *First aid at work*.¹⁶

Risks arising from motive power

58 Lift trucks are mostly powered by electric batteries or by internal combustion engines. There are risks associated with each which call for proper precautions, such as the provision of good ventilation and the elimination of risk of ignition.

59 When the batteries of battery-powered lift trucks are being charged, care should be taken to avoid a risk of explosion from an accumulation of hydrogen gas. Charging should only take place in a clearly marked area set aside for the purpose, away from the work or storage area and any main thoroughfare. The charging area should be cool, well ventilated, designated 'No smoking and no naked lights', and be free from other sources of ignition. Before charging takes place, the battery electrolyte levels should be checked to ensure that they are within the limits specified by the manufacturer and topped up if they are below the minimum level.

60 The manufacturer's instructions should be followed when charging batteries. Main covers and lids should be opened or removed where indicated. The lift truck, charger and all electrical connections should comply with the requirements of the Electricity at Work Regulations 1989 concerning installation, maintenance and use. Guidance on these Regulations is given in *Memorandum of guidance on the Electricity at Work Regulations*.¹⁷ Before the charger is disconnected from the battery or lift truck on charge, the current should be switched off to reduce the risk of a spark. Battery charging should not be carried out by untrained personnel.

61 In workplaces where lift trucks are powered by internal combustion engines it is important that the ventilation should be adequate to remove exhaust fumes, and that the engines should be properly maintained. Exhaust fumes may be significantly reduced by the use of filter systems or catalytic converters. However, these systems are not a substitute for providing adequate ventilation. Exhaust filters should be checked regularly in order to maintain their effectiveness. Petrol and liquefied petroleum gas (LPG)-engined lift trucks are particularly hazardous in confined spaces and should not be used there. Guidance on the Confined Spaces Regulations 1997 is given in the Approved Code of Practice *Safe work in confined spaces*.¹⁸

62 Areas used for fuelling diesel or petrol-engined lift trucks should be outside buildings. The local petroleum licensing officer can advise on the standard necessary to comply with the Petroleum (Consolidation) Act 1928. Notices prohibiting smoking should be clearly displayed in these areas and engines should be switched off before fuelling. Guidance on the storage of flammable liquids can be found in *The storage of flammable liquids in tanks*¹⁹ and *The storage of flammable liquids in containers*.²⁰

63 The fuel cylinders of LPG-engined lift trucks should preferably be changed outside buildings away from pits, drains, lift shafts and sources of ignition and in any case in an area that is adequately ventilated and where notices prohibiting smoking are clearly displayed. If the lift truck is fitted with integral tanks or if

employers refill their own cylinders, the installation for refilling should comply with the advice given in the LPGA Code of Practice 1 *Part 1, Bulk LPG storage at fixed installations*.²¹ Further information on the use of LPG can be obtained from the LPG Association. All refillable cylinders are considered to be transportable pressure receptacles for the purposes of the Carriage of Dangerous Goods (Classification, Packaging and Labelling) and Use of Transportable Pressure Receptacles Regulations 1996.²²

64 Due to the risk of explosion, petrol- and LPG-engined lift trucks should not be used in areas where there is a risk of a flammable vapour, gas or dust concentration being present.

65 Battery-powered lift trucks should only be used where there is a risk of a flammable vapour, gas or dust concentration being present if they have been suitably protected. Advice should be sought from the manufacturer or authorised supplier before use or before any modifications are carried out.

66 Diesel-powered lift trucks should only be used in potentially explosive atmospheres if, in addition to protection of the electrical system, the exhaust is protected against spark emission, precautions are taken against the intake of flammable mixtures and hot surfaces are protected. The advice of the lift truck manufacturer or authorised supplier should always be sought. For more detailed advice see *Lift trucks in potentially flammable atmospheres*.²³

Attachments

67 Fitting an attachment may alter the characteristics of the lift truck and is likely to necessitate a reduction in the actual capacity of the lift truck. Where this is necessary it should only be carried out by a lift truck engineer or another person with equivalent qualifications. Alternatively it may be necessary to use a lift truck with a larger capacity. Wherever possible, the manufacturer or authorised supplier should be consulted about the suitability of an attachment for a particular lift truck and the necessary derating. An additional capacity plate showing the derating necessary should be fitted to the truck. The derating should be related to an identified attachment.

68 Attachments may be mounted on the fork arms or directly onto the carriage. In all cases the attachment should be securely fastened and care taken to ensure that the attachment or securing device does not foul any part of the mast structure during raising or lowering of the attachment. The instructions for use of the attachment supplied by the manufacturer or authorised supplier should be followed at all times.

69 At the start of each shift the security of any attachment fitted to the lift truck should be checked and any defects reported immediately. Where defects are found which may affect the safe operation of the lift truck, it should not be used until such defects are rectified.

70 A wide range of removable attachments is available for use with lift trucks. Those illustrated and described here are some of the more common ones currently in use, though no description is made of some of the more specialised attachments used with telescopic materials handlers such as bale grabs and silage forks.

Fork arm extensions

These may be hydraulically operated telescopic fork arms replacing the fixed fork arms or simple box sections which may be slipped onto the fork arms and secured in place. They may be used to reach loads in deep racking or to handle extra depth loads.

Side shift carriage

This attachment may be mounted either on the existing fork carriage or in place of it. A side shift carriage enables horizontal sideways movement of the fork arms to allow precise positioning.

Fork positioner

This is a hydraulically operated attachment which allows the operator, while remaining in the operating position, to change the position of the fork arms relative to each other. The fork arm centres can therefore be adjusted to accommodate different load widths.

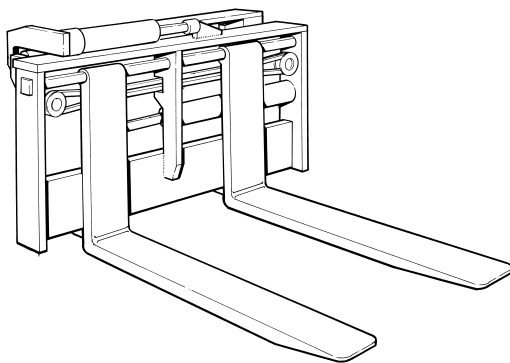

Figure 16 Side shift carriage

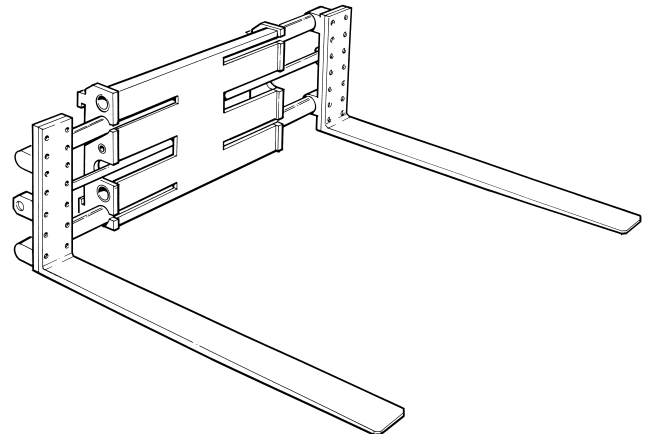

Figure 17 Fork positioner

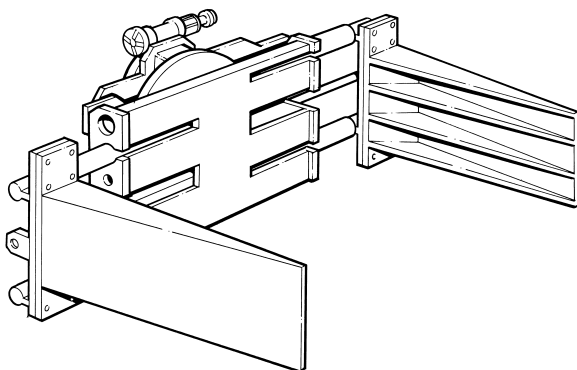

Figure 18 Rotator and clamps

Rotator

This attachment is mounted on the fork carriage and usually used in conjunction with another attachment. It allows the load to be rotated vertically about an axis parallel to the longitudinal axis of the lift truck. Some rotators have the facility to tilt the load forward from the vertical to the horizontal and beyond and are usually known as 'tipplers'.

Clamps

These attachments are designed for a variety of purposes such as lifting reels, bales or cartons. They may be used in conjunction with a rotator. The clamps may be faced with rubber or other material to improve grip.

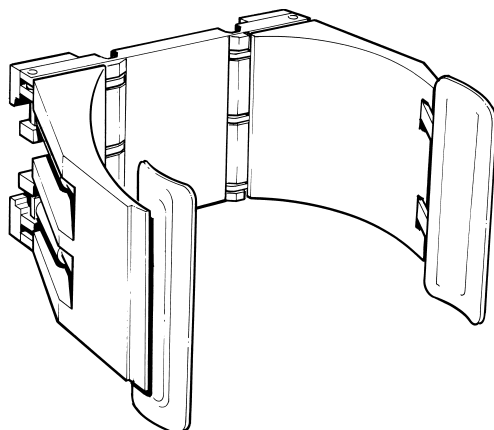

Figure 19 Paper and reel clamp

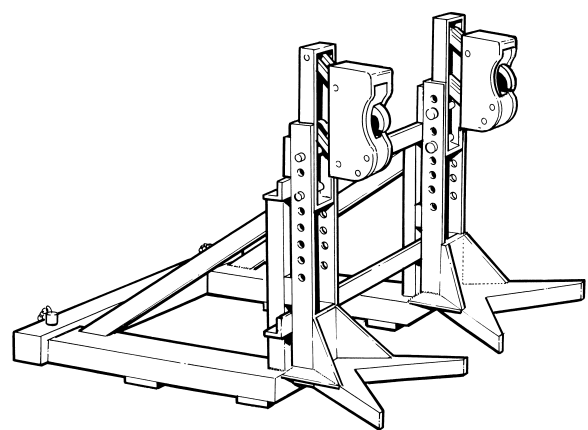

Figure 20 Automatic double-drum clamp attachment

Crane jib

This attachment may be mounted directly on the fork carriage or carried on the fork arms. A crane jib may be of a fixed length or extendible or embody a number of lifting points. On some it is possible to vary the angle of the jib from the horizontal.

Hydraulically operated hoppers

These attachments are usually carried on the fork arms. They are fitted with a mechanism which, when operated, causes the hopper to roll forward and discharge its contents. Once empty, the hopper returns to its normal position and re-engages the holding mechanism.

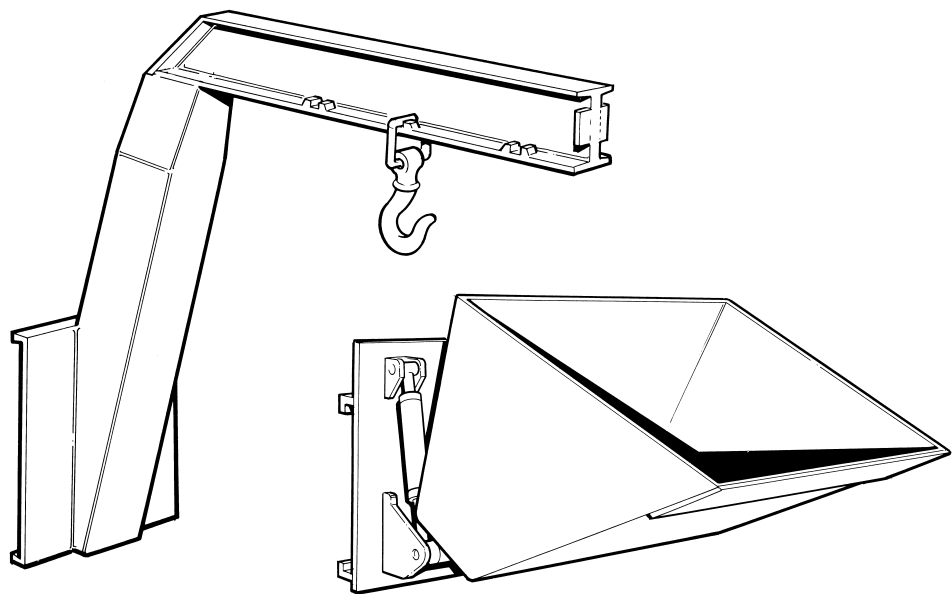

Figure 21 Crane jib attachment

Figure 22 Hydraulically operated hopper

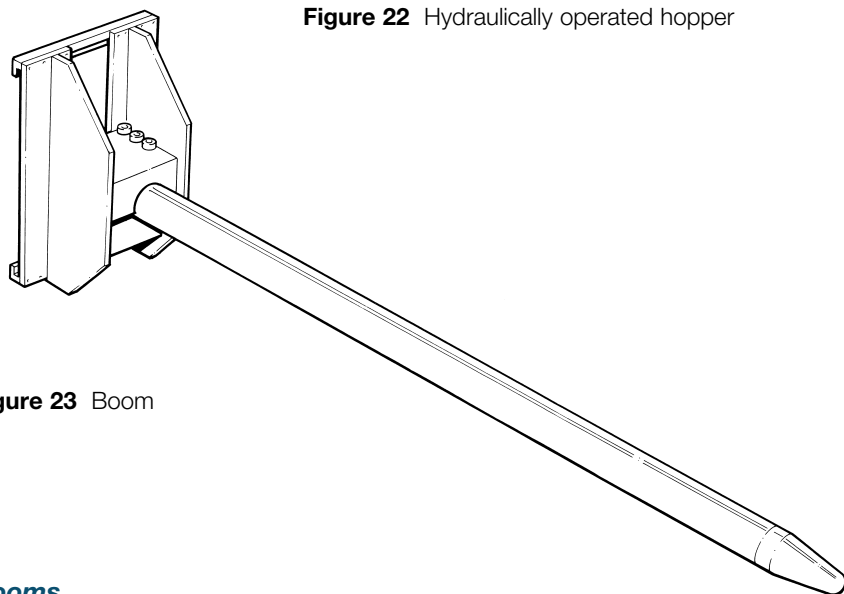

Figure 23 Boom

Booms

These attachments usually consist of a circular section pole mounted on the fork carriage. Designed for lifting rolls of carpet, coils of wire or similar cylindrical loads, they come in a variety of diameters and lengths.

Operation of lift trucks

71 Although no substitute for proper training, the following simple rules are set out for the benefit of lift truck operators and their supervisors, and should always be followed.

Dos and Don'ts

Do:

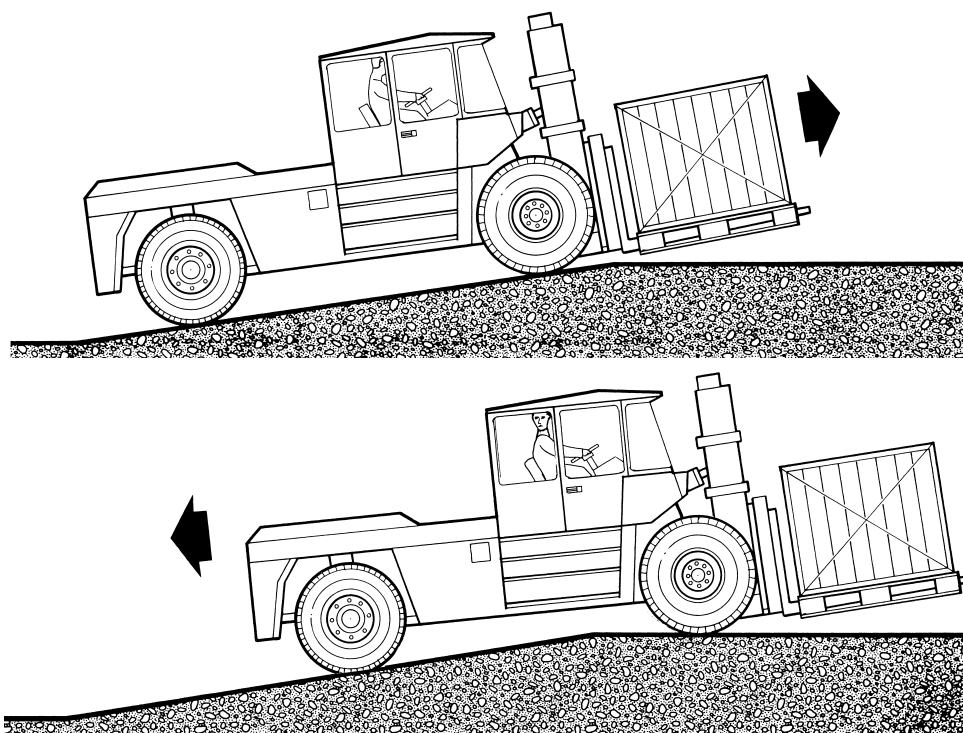

Figure 24 Travelling up and down slopes when loaded

- issue keys or other activating devices for lift trucks to authorised operators only, who should retain them until the end of the work period;
- on completion of work, park the lift truck in the designated parking area with the fork arms lowered to the ground and clear of walkways, with the parking brake applied and engine switched off. Shut off the power on battery-powered trucks. Turn off the gas on gas-powered lift trucks. Return keys or other activating devices to their place of safe keeping;

- be particularly careful when operating where there are pedestrians. Observe the site rules and take all precautions to avoid pedestrians. Pedestrians and vehicles should be separated wherever possible;
- as a general rule, when operating, keep to the left. However, when driving between rows of machines or racks it may be safer (if a clear view can be obtained) to keep to the centre of the gangway or aisle;
- sound the horn in short sharp blasts at every potential danger spot. Remember, the horn does not give automatic right of way;
- stop before doorways. Sound the horn and proceed slowly if clear to do so;
- avoid violent braking or sudden change of direction which may cause the load to fall off or the lift truck to tip.
- where possible, travel with the fork arms lowered to within 150 mm (6") of level ground and mast tilted slightly back. With some attachments, for example barrel clamps, the load should be kept level. Always follow the instructions for use of the attachment;
- always look in the direction of travel. When loaded, travel down or up slopes with the fork arms facing uphill (Figure 24). When unloaded, travel up or down slopes with fork arms facing downhill. It may be necessary to raise the fork arms slightly at the bottom of slopes to avoid grounding the load or fork arms. Where it is impossible or hazardous to turn the lift truck to comply with the above, for example when loading containers using a portable ramp, operate with the fork arms facing uphill for both directions of travel. In this case keep the lift truck in line with the incline and do not attempt to turn until on a level surface. Do not turn on or travel across a ramp or incline;

- travel slowly when descending slopes;
- when leaving the lift truck, even for a few seconds, apply the parking brake, make sure the controls are in neutral and the fork arms are tilted forward and lowered to the ground. If the lift truck is to be out of sight or remote, shut off the power and remove the key or other activating device;
- before raising a load ensure there is sufficient clearance overhead to do so and that objects which could fall and injure people nearby will not be dislodged;
- when mounting or dismounting from the lift truck use the steps and handholds provided for the purpose. Before dismounting, check that it is safe to do so and that the lift truck is parked safely.

Don't:

- lift a person on the forks unless a safe working platform is fitted;
- operate controls from outside the cab;
- stand on or near the controls to reach the load or anything outside the cab;
- allow operators to consume alcohol while at work. Even small quantities of alcohol can impair judgement and put the safety of the operator and others at risk;
- allow an employee who appears unfit through drink or drugs to operate a lift truck (a person who would be unfit to drive a vehicle on the public road should be considered unfit to operate a lift truck);
- pick up a load if someone is standing close to it;
- allow people to walk underneath the load;
- move a load that appears unsuitable, including one which is on a damaged pallet. Mark it as such and report its condition to the supervisor. Do not attempt to lift a load where the weight of the load is not known and it is believed that it may be approaching the maximum weight. When using wooden pallets follow the guidance in *Safety in the use of pallets*;²⁴
- leave a lift truck unattended/parked on a gradient except in an emergency, in which case chock the wheels to ensure that the truck cannot roll down the gradient. This should be done even if the truck will only be parked for a very short time and the operator remains in the vicinity (for example to attend to a problem with a load);
- carry passengers unless the lift truck is designed and equipped to do so;
- run over cables or flexible pipes etc that are on the floor unless they are suitably protected;
- travel with the load raised, because of the risk of overturning, except at creep speed as part of a stacking or de-stacking manoeuvre;
- carry a load that blocks forward visibility. If it is absolutely necessary to carry a bulky load which blocks visibility, then the lift truck should be driven in reverse. If this is not possible, for example when travelling up a slope, a responsible person should be appointed to be a banksman who, having a clear view of the path of the load, can give clear instructions to the operator. The banksman should be in a safe position and be in view or able to communicate effectively with the operator. If the banksman is unable to maintain a clear view of the path of the load then assistants who can do so will be necessary. Assistants also need to be in a safe position and either be in view of, or otherwise be able to communicate effectively with, the responsible person. Everyone involved in such exercises needs to use the same reliable means of effective communication (see *Safety signs and signals*⁹ or BS 6736 *Code of practice for hand signalling for use in agricultural operations*²⁵).

Stacking and de-stacking

72 General principles which apply are:

- (a) Lift trucks can become unstable when the mast is being raised or lowered because its centre of gravity is changing, whether loaded or not. Therefore, before the mast/boom is raised/lowered or extended, the truck should be stationary with the parking/handbrake applied and transmission disengaged before the hydraulics are used. However, on some rough-terrain machines it may be necessary to make minor adjustments while in motion to allow for uneven ground.
- (b) Stacking and de-stacking should not be attempted on inclines since the lift truck could overturn as the load is lifted, and the stack itself may be unstable;
- (c) If the fork tips extend beyond the load make sure they do not contact other loads in the rack etc;
- (d) Loads should be against the vertical face of the fork arms or load back-rest extension;
- (e) Adjust the fork spread to suit the load.

73 Paragraphs 74–103 refer to stacking and de-stacking with lift trucks equipped with fork arms. Similar procedures should be followed when loading or unloading lorries, trailers etc and when using attachments, except that with some attachments the mast should remain vertical at all times. The instructions of the manufacturer or authorised supplier should be followed.

Stacking with counterbalance lift trucks

74 The procedure for stacking with counterbalance lift trucks is as follows:

- (a) Before lifting, assess the weight of the load and its centre of gravity to ensure that the load does not exceed the capacity of the lift truck;
- (b) Approach the stack with the load low and tilted backwards. Slow down and stop at the face of the stack, apply the parking brake, select neutral if applicable, and reduce the backward tilt to an amount just sufficient to stabilise the load (Figure 25a);
- (c) Look up and check for obstructions then raise the load to the desired stacking height (Figure 25b);

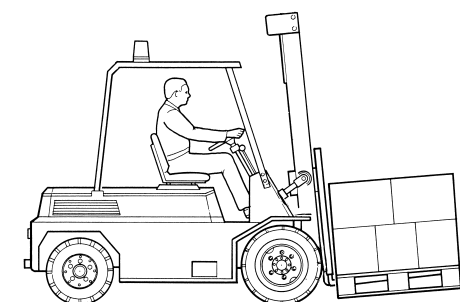

Figure 25a

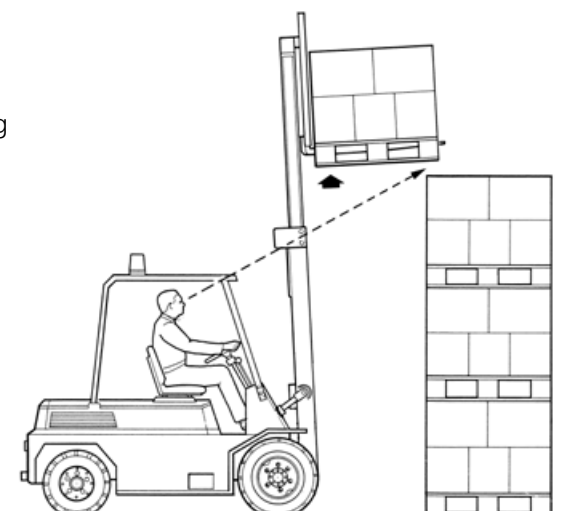

Figure 25b

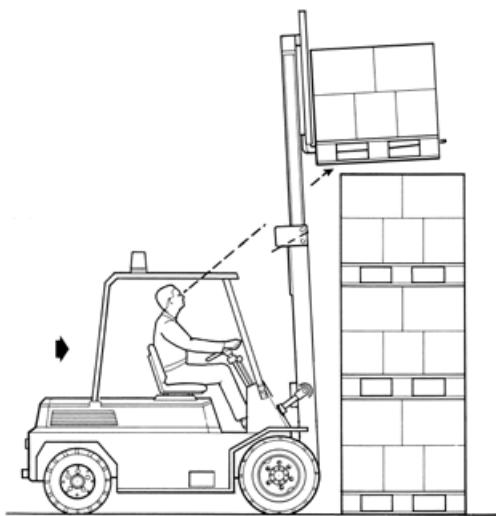

Figure 25c

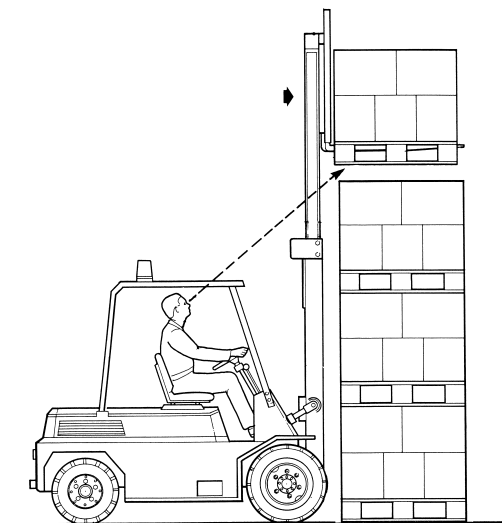

Figure 25d

- (d) Move slowly forwards, taking care not to dislodge loads in adjacent stacks (Figure 25c);
- (e) When the load is over the stack, stop, apply the parking brake and select neutral if applicable. Reduce the backtilt until the load is level, then slowly and smoothly lower the load onto the stack (Figure 25d);
- (f) When the load is securely stacked, lower the fork arms until free of the pallet or dunnage strips. After ensuring the way is clear, withdraw by reversing the lift truck, keeping a continuous lookout front and rear. Great care must be taken to ensure that the forks do not bind on withdrawal. If necessary adjust the tilt to clear (Figure 25e);
- (g) When clear of the stack, apply the parking brake and select neutral if applicable. Lower the fork arms to just above ground level, apply a slight backtilt, and check that the way is clear before moving off (Figure 25f).

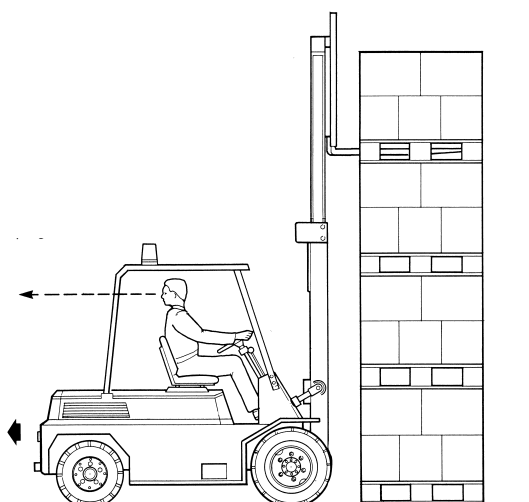

Figure 25e

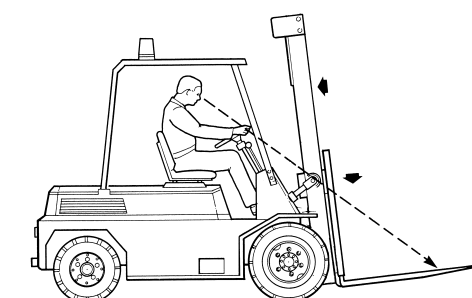

Figure 25f

De-stacking with counterbalance lift trucks

75 The procedure for de-stacking is as follows:

- (a) Halt at the face of the stack and apply the parking brake, selecting neutral if applicable. Bring the mast to the vertical position. If necessary, adjust the fork spread to suit the width of the load and ensure that the weight of the load is within the capacity of the lift truck (Figure 26a);
- (b) Look upwards, raise the fork arms to a position permitting clear entry into the pallet or dunnage strips (Figure 26b);

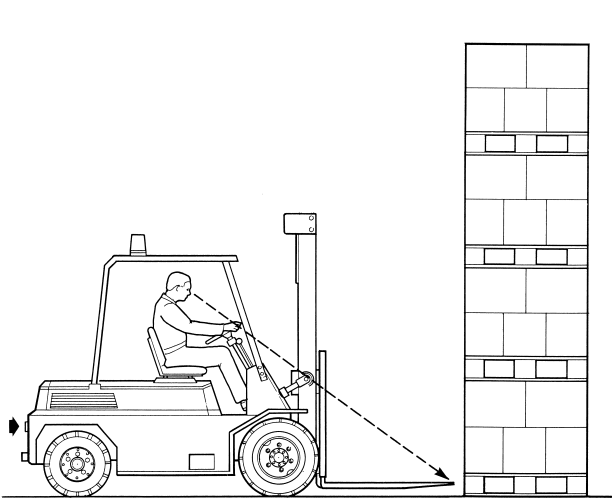

Figure 26a

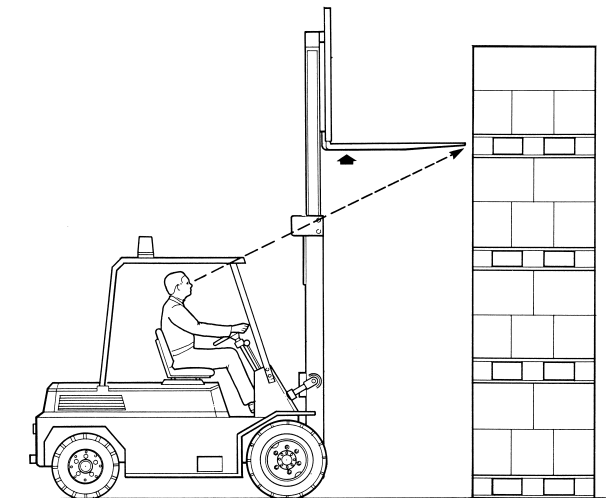

Figure 26b

- (c) Fully insert the fork arms by slowly driving forward until the heels of the forks gently touch the load or pallet base, and apply the parking brake, selecting neutral if applicable (Figure 26c);
- (d) Lift the load clear of the stack and carefully apply a backward tilt, just sufficient to stabilise the load (Figure 26d);

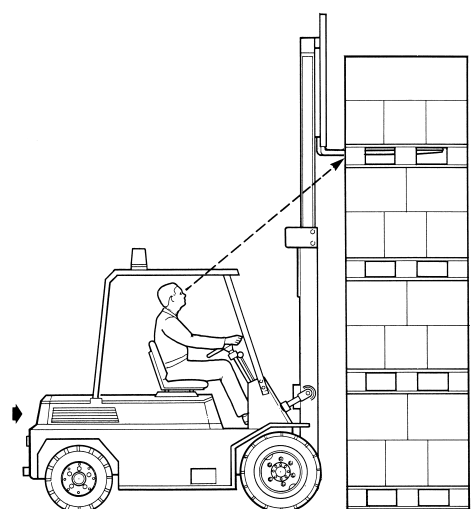

Figure 26c

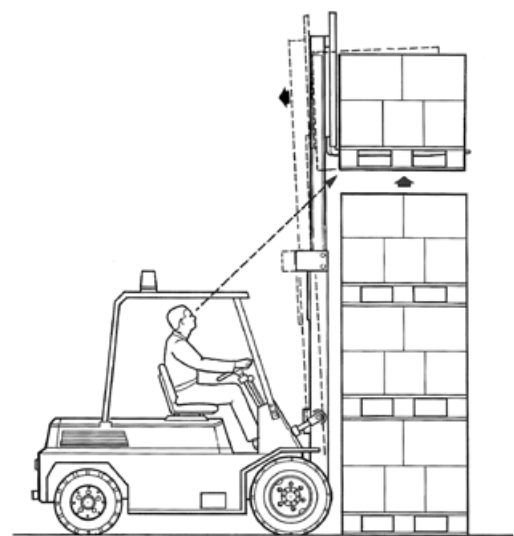

Figure 26d

- (e) check that the way is clear, then move slowly backwards until the load and fork arms are clear of the face of the stack, taking care not to dislodge loads in adjacent stacks and apply the parking brake, selecting neutral if applicable (Figure 26e);

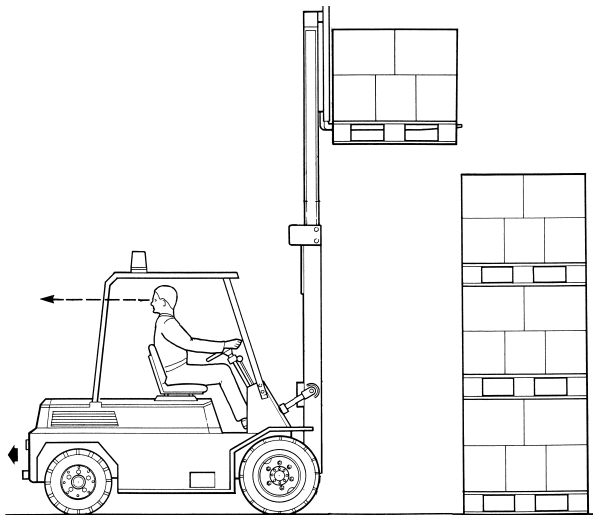

Figure 26e

- (f) lower the load carefully and smoothly to the correct travelling position, applying a further backward tilt. Check to see the way is clear before moving off (Figure 26f).

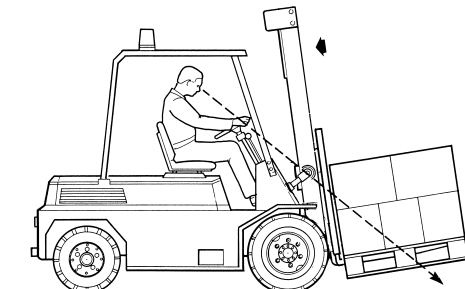

Figure 26f

Reach trucks

76 Reach trucks should not be driven, whether loaded or not, with the reach mechanism extended except when inching at the face of the load, stack or rack. The parking brake should be applied before operating the reach mechanism. No one should step over the reach legs or put any part of their body between the mast and power unit if the reach truck is capable of being operated. The reach movement should not be used for pushing or dragging loads and the load should be carried on the fork arms and not resting on the reach legs unless the reach truck is specifically designed for the purpose.

Stacking with reach trucks

77 Operators of reach trucks should observe the following basic stacking rules:

- (a) Approach the stack with the load low, reached in and tilted slightly backwards (Figure 27a);

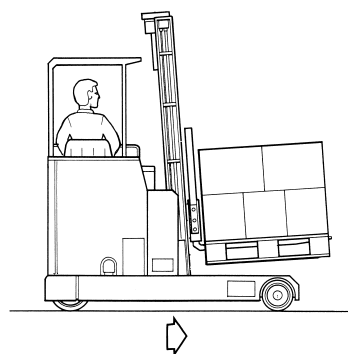

Figure 27a

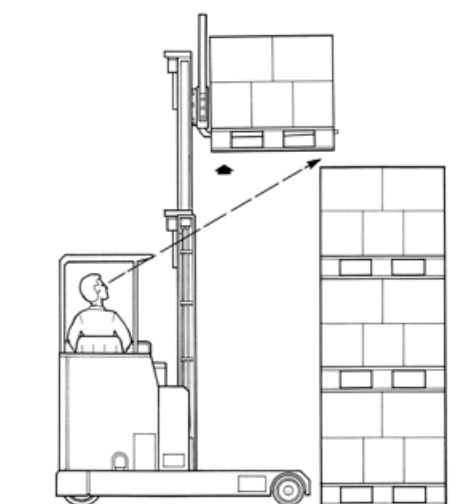

Figure 27b

- (b) Slow down and stop at the face of the stack, apply the parking brake, select neutral if applicable, and reduce the backward tilt to an amount just sufficient to maintain the load stability. Look up and check for obstructions, then raise the load to the desired stacking height (Figure 27b);

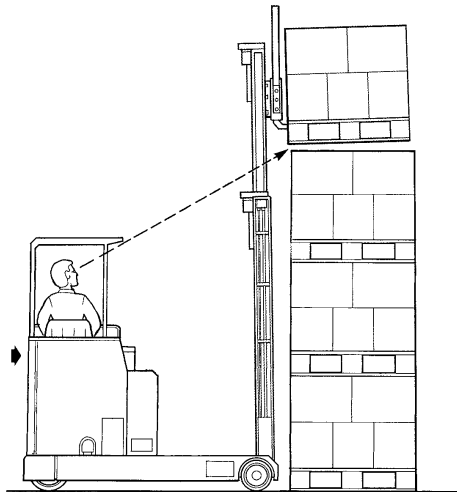

Figure 27c

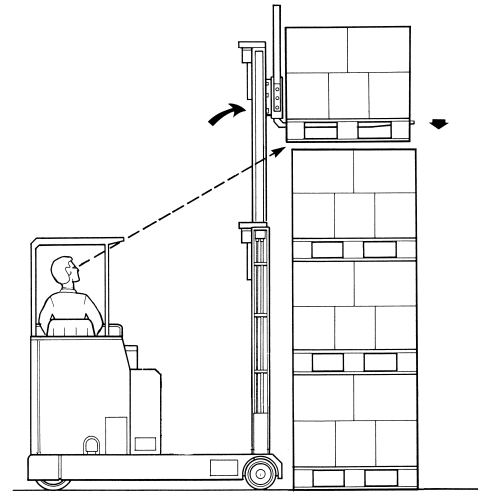

Figure 27d

- (d) Move forward if necessary, to bring the reach truck close to the stack, and reapply the parking brake, selecting neutral if applicable. Reach out smoothly, taking care not to dislodge loads in adjacent stacks (Figure 27c);
- (e) When the load is squarely over the stack, level the load and lower it onto the stack gently and smoothly (Figure 27d);
- (f) When the load is securely stacked, lower the fork arms until free of the pallet or dunnage strips and reach in. When freeing the fork arms, great care must be taken to ensure the forks do not bind on withdrawal. Adjust the tilt as necessary. (If the fork arms are not fully clear of the stack, the reach truck should be moved back a short distance, after ensuring the way is clear.) (Figure 27e);
- (g) When the fork arms are clear of the stack, reapply the parking brake if the reach truck has been moved, selecting neutral if applicable. Lower the fork arms to just above ground level, apply a slight backtilt, and check the way is clear before moving off (Figure 27f).

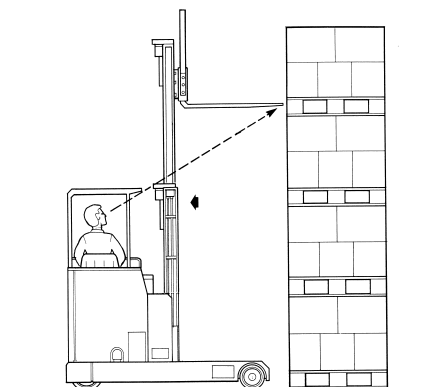

Figure 27e

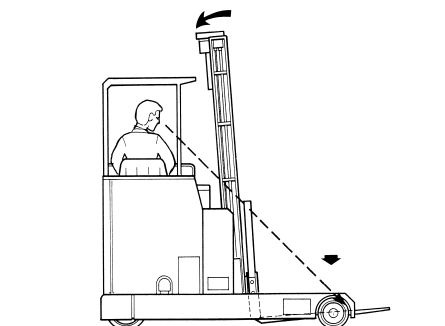

Figure 27f

De-stacking with reach trucks

78 Operators of reach trucks should observe the following basic de-stacking rules:

- (a) Halt at the face of the stack and apply the parking brake, selecting neutral if applicable. Bring the mast to the vertical position. If necessary, adjust the fork arm spread to suit the width of the load and ensure that the weight of the load is within the capacity of the reach truck (Figure 28a);
- (b) Look up and check for obstructions, then raise the fork arms to a position permitting clear entry into the pallet or dunnage strips (Figure 28b);

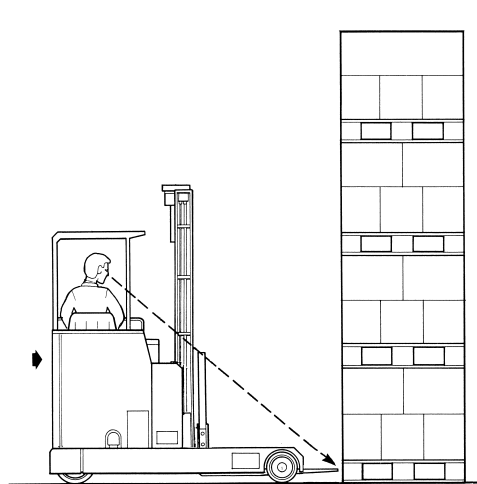

Figure 28a

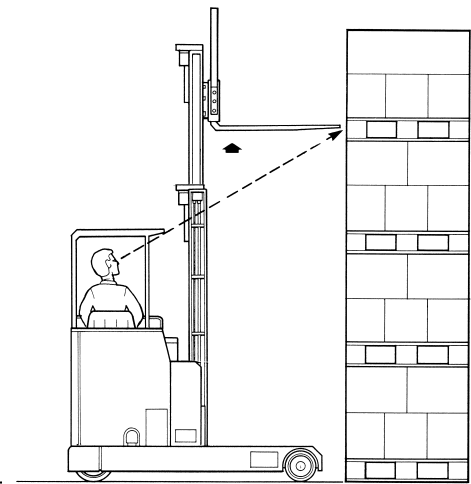

Figure 28b

- (c) Move forward if necessary, to bring the reach truck close to the stack and re-apply the parking brake, selecting neutral if applicable. Fully insert the fork arms by reaching out until the heels of the forks gently touch the load or pallet base (Figure 28c);
- (d) Lift the load until it is clear of the stack and carefully apply a backward tilt just sufficient to stabilise the load and reach in (Figure 28d);

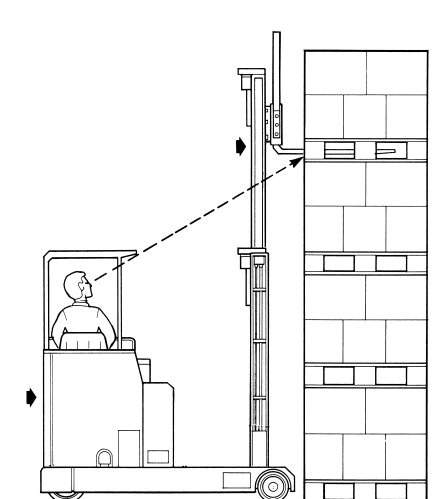

Figure 28c

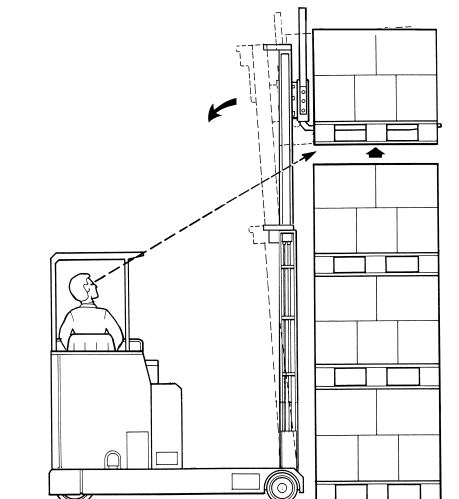

Figure 28d

- (e) If necessary, move the reach truck slightly backwards away from the stack, ensuring that the way is clear and taking care not to dislodge loads in adjacent stacks. Re-apply the parking brake, selecting neutral if applicable, if the reach truck has been moved (Figure 28e);

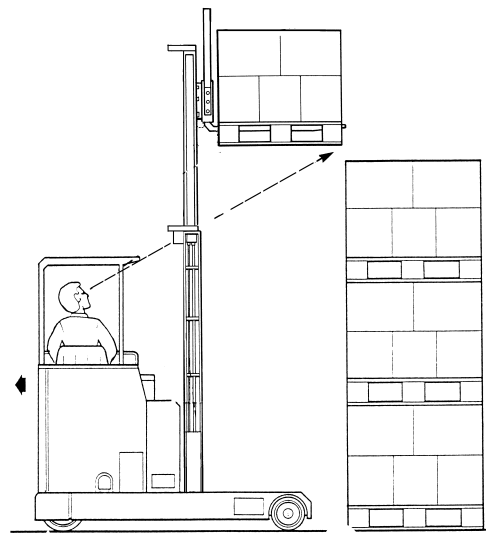

Figure 28e

- (f) Lower the load carefully and smoothly to the correct travelling position, applying the requisite backtilt before checking the way is clear and moving off (Figure 28f).

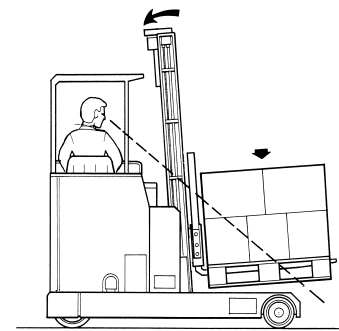

Figure 28f

Working platforms

79 People should never be lifted on the fork arms or a pallet balanced on the fork arms of a lift truck because they can easily fall off. However, although equipment such as lift trucks and telescopic materials handlers are primarily designed for the purpose of handling materials, when fitted with a suitably designed working platform they can provide a safer alternative to other means of access (such as a ladder). This arrangement will not provide the same level of safety as purpose-built equipment such as a mobile elevated work platform (MEWP). Where it is reasonably practicable to obtain and use purpose-built equipment for lifting people, particularly for regular and/or routine operations then such equipment should be used. Regulation 9 of the Lifting Operations and Lifting Equipment Regulations 1998 requires lifting equipment (including lift trucks and working platforms) used for lifting people to be thoroughly examined by a competent person at least once every six months or in accordance with an examination scheme, and each time that exceptional circumstances which are liable to jeopardise the safety of the lifting equipment have occurred.

Masted rough-terrain counterbalance lift trucks

80 The basic principles of lift truck operation apply to these machines but there are some additional factors that need to be considered in their operation.

81 To control a lift truck on rough terrain it is important to ensure adequate traction between the tyres and the ground. Traction is affected by several factors including:

- (a) the nature of the terrain. Travel routes should be chosen or prepared to avoid steep inclines, slippery gradients, and unstable or uncompacted ground. Loss of control may also occur as a result of bouncing when crossing rough ground;

(b) the weight over the drive wheels. An increase in the weight over the drive wheels will increase traction. So, for example, a loaded lift truck may be able to climb a slope safely but not be able to descend the same slope if unladen. Loss of control is more likely to occur with two-wheel drive lift trucks than four-wheel drives, but generally lift trucks can obtain sufficient grip to climb inclines steeper than those they descend safely. The manufacturer's data should be consulted when assessing whether a particular lift truck is suitable for its proposed use.

82 On some machines the parking brake cannot hold the machine on the steep inclines which it is able to climb. Operators should be made aware of the limitations of their lift truck which should be included in the manufacturers' performance data contained in their instruction manual. Work areas should be arranged in such a way that lift trucks do not have to stack or de-stack on an incline.

83 Stacking to high levels should only be carried out on reasonably level, well-drained ground that is well consolidated and is away from any excavation or wall.

84 When travelling, the fork arms should always be lowered but should be clear of the ground and any obstructions, and the mast should be tilted slightly backwards. When raising a load, care must be taken to ensure that there are no overhead obstructions. A load should never be lifted where there is a possibility of contact with or arcing from overhead power lines. Further guidance may be found in *Avoidance of danger from overhead electric power lines*.²⁶

85 If a lift truck is to be driven unladen on public roads, the fork arms should be removed, folded or protected in some way to avoid presenting a hazard to other road users. The lift truck should be cleaned of any material likely to fall on the road and cause danger to other road users.

Telescopic materials handlers

86 The same basic principles of operation apply to these lift trucks as to all others, including rough terrain, but with a number of important additions. The range of types available is large. They may be two- or four-wheel drive, and have two-wheel, four-wheel, crab steer or articulated steering.

87 The ability of telescopic materials handlers to raise loads to greater heights than conventional lift trucks increases the hazards of operation, particularly that of overturning. To counteract this latter hazard some types are equipped with stabilisers or chassis levelling devices. See page 16 for advice on ROPS and seat restraints.

88 The telescopic action of the boom presents an additional instability problem which operators need to understand. Although tipping sideways is recognised as a significant hazard, operators should also be aware of the danger of tipping forwards. Extension of the boom is a major factor which can cause this to happen and therefore the boom should be fully retracted for travelling, except at creep speed.

89 If the truck is fitted with stabilising jacks, the operator should be aware of the lifting capacity with and without the jacks down. If used, the jacks should be on firm, level ground. The operator should also be familiar with limitations concerning the use of axle locks and lateral levelling.

90 The load capacity of the truck will vary according to the extension of the boom and its degree of elevation. The manufacturer's specifications should be observed at all times.

91 Many telescopic materials handlers are used with a variety of attachments which may affect the stability of the machines. The manufacturer's or authorised supplier's recommendations for fitting and using attachments should be followed.

92 Operators and supervisors should be aware that attachments will alter the rated lift capacity and centre of gravity of the machine.

93 Machines should normally be fitted with Rated Capacity Indicators (RCI), often known as Load Moment Indicators. These give warning of approaching overload and should always be switched on during load handling operations. RCIs must be maintained and tested according to the manufacturer's or authorised supplier's instructions as part of the inspection regime required under PUWER. Operators should be made aware that it is an offence to interfere intentionally with the proper working of such a device (Section 8 of the HSW Act).¹

94 Lift trucks fitted with RCIs should not be used if it is suspected that the RCI is not working or is defective. The RCI is provided as an additional safety device and should not be used solely as an indicator of the limits of the machine.

95 For stacking or loading with a telescopic materials handler a firm, level site should be selected. Items should be transported with the boom as low as is practicable. On many machines the visibility to the right-hand side can be completely obscured if the boom is raised to certain positions. Because of this limitation particular care needs to be taken in areas where there may be pedestrians. It may be necessary to fit visibility aids or employ a banksman. Banksmen should be in a safe place and visible to the operator at all times.

96 When travelling up or down slopes with a load, the boom should face uphill. As far as possible avoid travelling across slopes.

97 When travelling on public roads, attachments and loads should be carried in such a way that they do not present a hazard to other road users. The boom should be in the lowest practicable position.

98 Before loads are raised, a check should be made for overhead obstructions. Loads should not be raised where there is a possibility of contact with or arcing from overhead power lines.

99 Restraining systems, such as seat belts should be worn whenever there is a risk of injury due to overturning. Doors should be kept shut to prevent the operator being ejected and crushed in the event of an overturn.

Side-loading lift trucks

100 The mast should be in when travelling unless the side-loader is specifically designed to allow travelling with the mast out. The load should be raised clear of the deck before the mast is traversed in, unless palletised or similar loads are being handled in the truck well. The truck should travel with the load securely on the deck and the fork arms just clear. The capacities of the truck, both with its stabilising jacks in use and without them, should be clearly marked and visible to the operator. When stabilising jacks are in use they should be hard down on firm ground, or suitable packing should be used.

Pedestrian-controlled lift trucks

101 Operators of pedestrian-controlled lift trucks should always face the direction of travel. They should, wherever possible, walk with the control handle to one side of them when travelling with the lift truck behind them. If travelling on ramps the load should always face uphill. Operators should not ride on pedestrian-controlled trucks unless these are also specifically designed as a powered stand-on truck.

102 In an emergency, the operator should completely release the control handle allowing it to function as a 'dead man's handle'.

103 When reversing from a stack, operators should first ensure there is sufficient standing space between the control handles and the stack, rack or wall behind. Where manoeuvring space is limited, care should be taken to ensure that the operator does not become trapped between the control handle and other objects or fixtures.

Trailers and loading platforms

104 Permanent loading platforms, as used in warehouses or in factories, should be constructed and designed to carry the foreseeable maximum load safely. Temporary loading platforms, as on building sites, should be clearly marked with the maximum load that they are designed to carry, and lift truck operators should be advised of this load. When manoeuvring, care should be taken to ensure that the lift truck does not damage the platform or its supporting structure.

105 Trailers of articulated lorries are less stable when they have been disconnected from their towing units. They should always be braked when they are being loaded. Because the lift truck may jolt the trailer which it is loading and cause the landing legs to collapse, consideration should be given to providing additional jacks for stability. Bridge plates, strong enough to support the lift truck and its load, should be provided and fixed securely if the lift truck has to drive onto the trailer for loading or unloading. If the deck of the trailer is not strong enough to support the weight of a lift truck and its load, an effective means, such as steel plates, should be used to distribute the weight of the wheel loads over an adequate area.

106 Where possible, additional means should be provided to prevent the unevenly loaded trailer moving or tipping during the loading operation. Bear in mind that trailers are particularly unstable and will upend.

Maintenance

107 The manufacturer's or authorised supplier's instructions on inspection, maintenance and servicing should be followed. Operators, unless suitably qualified and authorised, should not carry out repairs and adjustments to lift trucks. If lift trucks are hired, arrangements should be made to ensure proper inspection, maintenance and servicing. Where lift trucks are on long-term hire, users have a duty to ensure that they are safe for their employees to use and are thoroughly examined at appropriate intervals. These examinations may be arranged by users or hire companies by agreement. They do not remove the need for users to ensure that necessary inspections and pre-use checks are carried out and defects reported and remedied as necessary. The advice below is limited to the areas which should be considered on a day-to-day basis. Detailed advice on

maintenance, inspection, reports and records required under the Provision and Use of Work Equipment Regulations 1998 and the Lifting Operations and Lifting Equipment Regulations 1998 is given in *Safe use of work equipment*³ and *Safe use of lifting equipment*.⁴ These publications contain information on periodic thorough examination, the purpose and extent of inspections and the qualities required of people considered competent to carry them out (see paragraph 57a, page 19).

108 At the beginning of each shift the operator should check the lift truck and report to the supervisor any defects which might affect its safe operation to ensure they are put right. Checks should include:

- (a) tyre pressures: pneumatic tyres if fitted should be inflated to the proper pressure; incorrectly inflated tyres can affect the stability of the lift truck and the load. Tyres should also be checked for damage, for example swarf, nails and other embedded material, cuts and bubbles;
- (b) parking brake, service brakes, and steering gear to ensure that they are working efficiently;
- (c) fuel, water and oil in internal combustion-engined lift trucks for leaks and correct levels;
- (d) batteries of battery-operated lift trucks to check that they are adequately charged and leak free, that the charger is switched off, the charge lead disconnected and properly stored, and the battery retention device is in place;
- (e) systems for lifting, tilting and manipulation, including attachments. These should be working properly. Hydraulic systems should be free from obvious leaks, and hydraulic fluid levels should be correct when the fork arms are in the parked position;
- (f) audible warning signal;
- (g) lights;
- (h) mirrors, if fitted.

109 For lift trucks in constant use weekly checks are appropriate. These checks should include:

- (a) all the daily checks set out in paragraph 108;
- (b) an operational check of the steering gear, lifting gear, condition of the battery and other working parts;
- (c) the condition of the mast, fork arms, attachments, tyres and any chains or ropes used in the lifting mechanisms, and, if fitted, the operator restraint;
- (d) security of the overhead guard and load back-rest extension.

Appendix 1: Accrediting bodies

Information on training can be obtained from the following bodies, who are recognised by the Health and Safety Commission as competent to accredit and monitor lift truck training providers.

Association of Industrial Truck Trainers (AITT), Unit 20, The Springboard Centre (Coalville) Ltd, Mantle Lane, Coalville, Leicestershire LE67 3DW, tel: 01530 277857

Construction Industry Training Board, Bircham Newton, King's Lynn, Norfolk PE31 6RH, tel: 01485 577877 (CPCS helpline)

Independent Training Standards Scheme and Register (ITSSAR), Armstrong House, 28 Broad Street, Wokingham, Berks RG40 1AB, tel: 0118 9893229

Lantra National Training Organisation Ltd, NAC, Stoneleigh, Kenilworth, Warwickshire CV8 2LG, tel: 024 7669 6996 (information services helpline)

National Plant Operators Registration Scheme Ltd, PO Box 204, Northwich, Cheshire CW9 7FY, tel: 01606 49909

RTITB Ltd, Access House, Halesfield 17, Telford TF7 4PW, tel: 01952 520200

Appendix 2: Medical standards for lift truck operators

Introduction

1 The following notes give **advice** to occupational health professionals about the medical fitness of operators of rider-operated lift trucks. **The standard should be regarded as a guide which can be adapted to individual circumstances.**

2 Reference will be made to existing medical standards for drivers, and guidance will be provided on how to apply these standards and adapt them to prevailing circumstances by assessing the risks inherent in the work to be carried out.

Medical standards

3 Detailed advice on medical standards of fitness to drive can be found in *At a glance*²⁷ published by the Drivers' Medical Unit of the DVLA, Swansea. This is regularly updated and is available on the Internet at www.dvla.gov.uk or from the Medical Adviser, Drivers' Medical Unit, DVLA, Longview Road, Morriston, Swansea SA99 1TU (tel: 01792 783686 or 01792 2400009, fax 01792 761100). However, the DVLA does not have responsibility for licensing lift truck operators (provided they do not drive lift trucks on public roads). *At a glance*²⁷ should always be consulted where there is any doubt about an individual's fitness to operate a lift truck.

4 *At a glance*²⁷ lists separate medical standards for both Group 1 entitlement (holders of ordinary driving licence) and Group 2 entitlement (HGV and PSV licence holders).

Application of medical standards

5 Each person's fitness for operating a lift truck should always be judged individually. The underlying approach should be to match the requirements of the particular driving task with the fitness and abilities of the driver. For most work a standard equivalent to that of the Group 1 entitlement will be appropriate. In some cases, however, a more stringent standard may be required, for example when moving highly toxic or explosive materials, working in a particularly demanding environment, working at night, or if large, heavy trucks are to be operated. In these instances some or all of the medical standards equivalent to that of Group 2 entitlement may be appropriate.

6 Applying the principle of individual assessment of fitness should ensure that people with disabilities are not disadvantaged. Some people with disabilities have developed compensatory skills. Reasonable adjustment to work equipment, as can be required by the Disability Discrimination Act 1995, may enable a disabled person to operate a lift truck safely. Competence in an emergency must, however, always be considered.

Frequency of assessment

7 All existing and potential lift truck operators should be screened for fitness before employment and at five-yearly intervals from age 40. Group 2 licences are renewable five-yearly from age 45 and, where an individual is both a lift truck operator and holds a Group 2 entitlement, these assessments can be made at the same examination. A lift truck operator who continues after age 65 should have annual assessments for fitness.

8 Assessment is also recommended after an absence of more than one month or after a shorter absence if it is likely that the illness may have affected fitness to operate lift trucks. This assessment is recommended to provide positive confirmation of fitness to operate lift trucks in these circumstances. Fitness to return to work when signed off by a GP may not indicate fitness to operate a lift truck.

9 Assessment is also appropriate if lift truck operators, or their employers, suspect that they have developed a condition which may affect their continuing ability to operate lift trucks.

10 It is advisable for employers to agree requirements for medical screening and/ or examination of employees, in advance, in a contract of employment.

Medication

11 Fitness to operate lift trucks may be impaired temporarily by the effects of medication, whether prescribed or purchased over the counter. Lift truck operators should seek advice from their general practitioner or the pharmacist about the potential effects any medication may have on their ability to drive safely, and should notify their employer if there is risk of adverse effects which may compromise safety. In some cases it may be necessary for them to stop operating lift trucks until the nature and extent of any side effects has been established.

Alcohol and illicit drugs

12 Lift truck operation should not be carried out in circumstances when either alcohol or drugs have been taken. Advice for employers on alcohol and drugs is provided in *Don't mix it: A guide for employers on alcohol at work*²⁸ and *Drug misuse at work: A guide for employers*.²⁹

The following is a summary of standards applicable to Group 1 drivers published by DVLA and is valid on the publication date of this document. Standards may change and reference to *At a glance*²⁷ is recommended. However, standards required for a particular work situation should be set, taking into account assessment of both health and safety implications and the physical and mental demands of the job. It may be necessary to obtain specific advice on standards from a suitably competent occupational physician who is familiar with the work environment in question. The Employment Medical Advisory Service (EMAS) located at HSE offices may be able to assist in locating such doctors.

Locomotor

- There are no specific restrictions on Group 1 entitlement. Standards will depend on the demands of the job but for lift truck operation there should normally be full movement of the trunk, neck and upper and lower limbs. Stable deformities such as an arthrodesed joint should be assessed according to the effect on functional ability and this may require the advice of a lift truck instructor.
- An experienced lift truck operator who loses a limb or part of a limb may be able to continue in employment after suitable retraining.

Diabetes mellitus

- When managed by diet alone or treated by tablets this condition is normally acceptable if well controlled, and if there are no complications, for example diabetic eye problems affecting vision.
- The use of insulin is normally acceptable as long as there is satisfactory control and recognition of warning symptoms of hypoglycaemia. Required visual standards must be met.
- Continuing fitness will need to be kept under review.

Cardiovascular conditions

Ischaemic heart disease

- History of a single uncomplicated myocardial infarction is not a bar to lift truck operation, but lift truck operation should cease for at least one month. This should be followed by medical assessment, lift truck operation may recommence thereafter, provided there is no other disqualifying condition.
- For angina, lift truck operation should cease until satisfactory control of symptoms is achieved. It will not be a bar unless occurring during lift truck operation or at rest, or unless medication produces side effects which may interfere with lift truck operation. Lift truck operation may recommence when satisfactory symptom control is achieved.
- A second or complicated myocardial infarction will require careful assessment in the light of residual function, risk factors etc.

Hypertension

- Lift truck operation may continue unless treatment causes unacceptable side effects.

Arrhythmia

- Lift truck operation must stop with an arrhythmia which may distract the operator's attention or render him or her liable to sudden impairment of cerebral function. Lift truck operation may resume when satisfactory control of symptoms is achieved provided that cardiac function is also satisfactory.

Other conditions

- In general, lift truck operation should cease for a month after any cardiac event, following which fitness should be reassessed.
- Other serious cardiac conditions, for example valvular disease with complications such as a history of cerebral ischaemia, are likely to be a bar to lift truck operation. Specialist advice should be sought in all cases of doubt.

Vision

- Operators must be able to read in good light (with the aid of glasses or contact lenses if required) a vehicle registration mark at a distance of 20.5 metres, with both eyes together. This corresponds to visual acuity of between 6/9 and 6/12 on the Snellen chart.
- Monocular individuals vary in their ability to compensate for their impairment and to operate a lift truck safely. Fitness to operate a lift truck cannot be assumed and, after medical assessment, this should be determined following practical lift truck operating tests. This approach should also be adopted for the experienced operator who becomes monocular, after allowing a period of adaptation.
- Visual field defects. Lift truck operation should cease unless an operator is confirmed able to meet the recommended national guideline for visual field. A full definition is provided in *At a glance*.²⁷
- Uncontrolled diplopia will disqualify an individual from operating a lift truck. Resumption may be permitted when satisfactory control of symptoms is achieved. Regular review is recommended.

Nervous system

- Vertigo, giddiness and disorders of balance. Lift truck operation should cease on diagnosis. Resumption may be permitted when satisfactory control of symptoms is achieved. Regular review is recommended.
- For neurosurgical disorders, including intracranial tumours and haemorrhage, detailed advice is given in *At a glance*.²⁷
- After acute illness, such as a stroke, lift truck operation should cease for at least one month. The extent of recovery should then be assessed. Where recovery is complete then lift truck operation may recommence. Progressive or relapsing conditions will require careful assessment of function and prognosis.
- Long-standing static deficits, such as weakness of a limb following poliomyelitis, should be assessed for functional ability. Lift truck operation may be practical, possibly with the help of suitable adaptation to the lift truck.

Epilepsy

- This will not normally be a bar to lift truck operation where an individual qualifies for an ordinary driving licence (ie has been free from epileptic attack for one year). Any necessary medication should be maintained, and a recurrence of seizures should result in a reassessment. If the individual no longer meets the requirements for a Group 1 entitlement he/she will not be fit for work as a lift truck operator.
- Annex 3 of *At a glance*²⁷ gives full details of the epilepsy regulations as prescribed by the Motor Vehicles (Driving Licences) Regulations 1996. This should be used as guidance to assess suitability for lift truck operation.

Hearing

- Hearing defects do not normally affect Group 1 entitlement. However, cases should be assessed individually, taking into account the working environment, materials being handled and other duties associated with the work. If good hearing is thought to be particularly important then this should be assessed audiometrically.

Alcohol and drugs

- An individual who is dependent on alcohol or drugs should not operate a lift truck. Where there is such a history there should be a clear period of freedom from dependence of at least one year before employment as a lift truck operator is considered. Medical assessment of fitness to operate a lift truck should then be carried out. Reference to *At a glance*²⁷ is recommended in individual cases.

Psychiatric disorders

- Suspicion or knowledge of psychiatric disorders should lead to suspension from lift truck operation pending medical assessment. Guidance is complex and *At a glance*²⁷ provides detailed advice under the following headings:

- (a) Anxiety or depression;
- (b) More severe anxiety or depressive illness;
- (c) Acute psychotic episodes of any type or cause;
- (d) Chronic schizophrenia;
- (e) Dementia or any organic brain syndrome;
- (f) Learning disability;
- (g) Persistent behaviour disorder.

References and further reading

References (HSE Books unless otherwise stated)

- 1 *Health and Safety at Work etc Act 1974* Ch 37 The Stationery Office 1974 ISBN 0 10 543774 3
- 2 *Management of health and safety at work. Management of Health and Safety at Work Regulations 1999. Approved Code of Practice and guidance L21* (Second edition) HSE Books 2000 ISBN 978 0 7176 2488 1
- 3 *Safe use of work equipment: Provision and Use of Work Equipment Regulations 1998. Approved Code of Practice and guidance L22* (Second edition) HSE Books 1998 ISBN 978 0 7176 1626 8
- 4 *Safe use of lifting equipment. Lifting Operations and Lifting Equipment Regulations 1998. Approved Code of Practice and guidance L113* HSE Books 1998 ISBN 978 0 7176 1628 2
- 5 *Workplace health, safety and welfare. Workplace (Health, Safety and Welfare) Regulations 1992. Approved Code of Practice L24* HSE Books 1992 ISBN 978 0 7176 0413 5

- 6 *Managing health and safety in construction. Construction (Design and Management) Regulations 2007. Approved Code of Practice L144* HSE Books 2007 ISBN 978 0 7176 6223 4
- 7 *Rider-operated lift trucks. Operator training. Approved Code of Practice and guidance L117* HSE Books 1999 ISBN 978 0 7176 2455 3
- 8 *Young people at work - A guide for employers HSG165* (Second edition) 2000 ISBN 978 0 7176 1889 7 (Out of print)
- 9 *Safety signs and signals. Health and Safety (Safety Signs and Signals) Regulations 1996. Guidance on Regulations L64* HSE Books 1996 ISBN 978 0 7176 0870 6
- 10 *Lighting at work HSG38* (Second edition) HSE Books 1997 ISBN 978 0 7176 1232 1
- 11 *Controlling noise at work. The Control of Noise at Work Regulations 2005. Guidance on Regulations L108* (Second edition) HSE Books 1998 ISBN 978 0 7176 6164 0
- 12 *Construction (Head Protection) Regulations 1989. Guidance on Regulations L102* (Second edition) HSE Books 1998 ISBN 978 0 7176 1478 3
- 13 *Workplace transport safety: An employers guide HSG136* (Second edition) HSE Books 2005 ISBN 978 0 7176 6154 1
- 14 *Health and safety in tyre and exhaust fitting premises HSG62* HSE Books 1991 ISBN 978 0 7176 1686 2
- 15 *Control of substances hazardous to health (Fifth edition). The Control of Substances Hazardous to Health Regulations 2002 (as amended). Approved Code of Practice and guidance L5* (Fifth edition) HSE Books 2005 ISBN 978 0 7176 2981 7
- 16 *First aid at work. Health and Safety (First-Aid) Regulations 1981. Approved Code of Practice and guidance L74* HSE Books 1997 ISBN 978 0 7176 1050 1
- 17 *Memorandum of guidance on the Electricity at Work Regulations 1989. Guidance on Regulations HSR25* (Second edition) HSE Books 2007 ISBN 978 0 7176 6228 9
- 18 *Safe work in confined spaces. Confined Spaces Regulations 1997. Approved Code of Practice, Regulations and guidance L101* HSE Books 1997 ISBN 978 0 7176 1405 9
- 19 *The storage of flammable liquids in tanks HSG176* HSE Books 1998 ISBN 978 0 7176 1470 7
- 20 *The storage of flammable liquids in containers HSG51* (Second edition) HSE Books 1998 ISBN 978 0 7176 1471 4
- 21 *Bulk LPG storage at fixed installations, Part 1* LPGA Code of Practice, LPG Association 2000, tel: 01425 461612

- 22 *Approved Carriage List: Information approved for the carriage of dangerous goods by road and rail other than explosives and radioactive material. Carriage of Dangerous Goods (Classification, Packaging and Labelling) and Use of Transportable Pressure Receptacles Regulations 1996. Carriage of Dangerous Goods by Road Regulations 1996. Carriage of Dangerous Goods by Rail Regulations 1996* L90 1999 ISBN 978 0 7176 1681 7 (Out of print)
- 23 *Lift trucks in potentially flammable atmospheres* HSG113 HSE Books 1996 ISBN 978 0 7176 0706 8
- 24 *Safety in the use of pallets* Plant and Machinery Guidance Note PM15 (Third edition) HSE Books 1998 ISBN 978 0 7176 1522 3
- 25 *BS 6736: 1986 Code of practice for hand signalling for use in agricultural operations* British Standards Institution
- 26 *Avoidance of danger from overhead electric power lines* General Guidance Note GS6 (Third edition) HSE Books 1997 ISBN 978 0 7176 1348 9
- 27 *At a glance* DVLA, Drivers' Medical Unit, Longview Road, Morristan, Swansea SA99 1TU, tel: 01792 783686 or 01792 2400009, fax: 01792 761100; also available on Internet at www.dvla.gov.uk
- 28 *Don't mix it: A guide for employers on alcohol at work* Leaflet INDG240 HSE Books 1996 (single copy free or priced packs of 10 ISBN 978 0 7176 1291 8) www.hse.gov.uk/pubns/indg240.pdf
- 29 *Drug misuse at work: A guide for employers* Leaflet INDG91(rev2) HSE Books 1998 (single copy free or priced packs of 10 ISBN 978 0 7176 2402 7) www.hse.gov.uk/pubns/indg91.pdf

Further reading

Safety in docks. Docks Regulations 1988. Approved Code of Practice with Regulations and guidance COP25 HSE Books 1988 ISBN 978 0 7176 1408 0

Petroleum (Consolidation) Act 1928 Ch 32 The Stationery Office 1928

Health and safety at quarries. The Quarries Regulations 1999. Approved Code of Practice L118 HSE Books 1999 ISBN 978 0 7176 2458 4

Personal protective equipment at work (Second edition). The Personal Protective Equipment at Work Regulations 1992 (as amended). Guidance on Regulations L25 (Second edition) HSE Books 2005 ISBN 978 0 7176 6139 8

The safe use of vehicles on construction sites: A guide for clients, designers, contractors, managers and workers involved with construction transport HSG144 HSE Books 1998 ISBN 978 0 7176 1610 7

While every effort has been made to ensure the accuracy of the references listed in this publication, their future availability cannot be guaranteed.

Further information

For information about health and safety ring HSE's Infoline Tel: 0845 345 0055
Fax: 0845 408 9566 Textphone: 0845 408 9577 e-mail: hse.infoline@natbrit.com or
write to HSE Information Services, Caerphilly Business Park, Caerphilly CF83 3GG.

HSE priced and free publications can be viewed online or ordered from
www.hse.gov.uk or contact HSE Books, PO Box 1999, Sudbury, Suffolk
CO10 2WA Tel: 01787 881165 Fax: 01787 313995. HSE priced publications are
also available from bookshops.

The Stationery Office publications are available from The Stationery Office,
PO Box 29, Norwich NR3 1GN Tel: 0870 600 5522 Fax: 0870 600 5533
e-mail: customer.services@tso.co.uk Website: www.tso.co.uk (They are also
available from bookshops.) Statutory Instruments can be viewed free of charge at
www.opsi.gov.uk.

British Standards can be obtained in PDF or hard copy formats from the BSI online
shop: www.bsigroup.com/shop or by contacting BSI Customer Services for hard
copies or by Tel: 020 8996 9001 email: cservices@bsigroup.com